



203664 - 09/23 - Co - Printed in Germany - Technische Änderungen vorbehalten - Subject to technical modifications

# ROBOTICS ADD ON: KI / AI

**fischertechnik GmbH**  
Klaus-Fischer-Str. 1  
72178 Waldachtal  
Germany

Phone: +49 74 43/12-43 69  
Fax: +49 74 43/12-45 91

info@fischertechnik.de  
www.fischertechnik.de

[www.fischertechnik.de](http://www.fischertechnik.de)

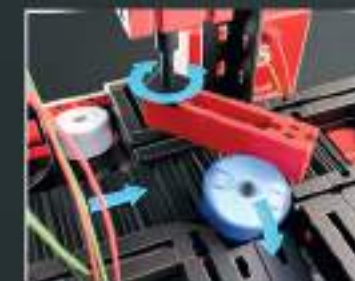

Bauanleitung  
Assembly instruction  
Instructions de montage  
Bouwhandleiding  
Instrucciones de construcción

Manual de montagem  
Istruzioni di montaggio  
Инструкция по сборке  
安装说明书

# ROBOTICS ADD ON: KI / AI

MODELS

**3**

**Inhalt**  
**Contents**  
**Contenu**

**Inhoud**  
**Contenido**  
**Conteúdo**

**Contenuto**  
**Содержание**  
**目录**

Einzelteilübersicht / Spare parts list / Liste des pièces détachées / Onderdelenoverzicht / Lista de piezas / Lista de Componentes /  
Singoli componenti / Перечень деталей / 零件概览 ..... 2

Montagetipps / Tips for assembly / Conseils d'assemblage / Montagetips / Consejos para el montaje / "Dicas" para montagem /  
Consigli per il montaggio / Советы по сборке / 装配建议 ..... 3

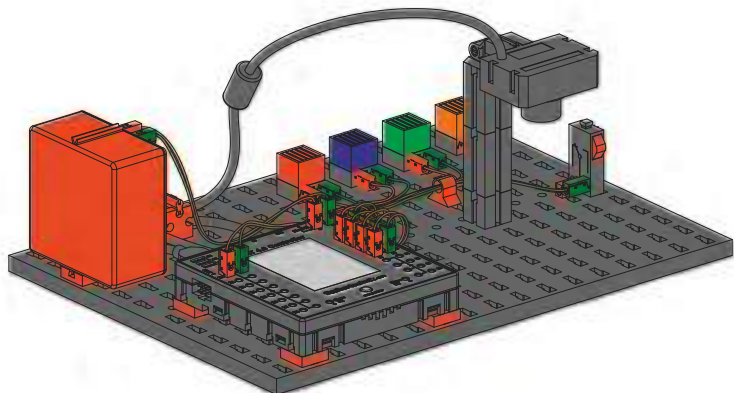

Teachable Machine ..... 5

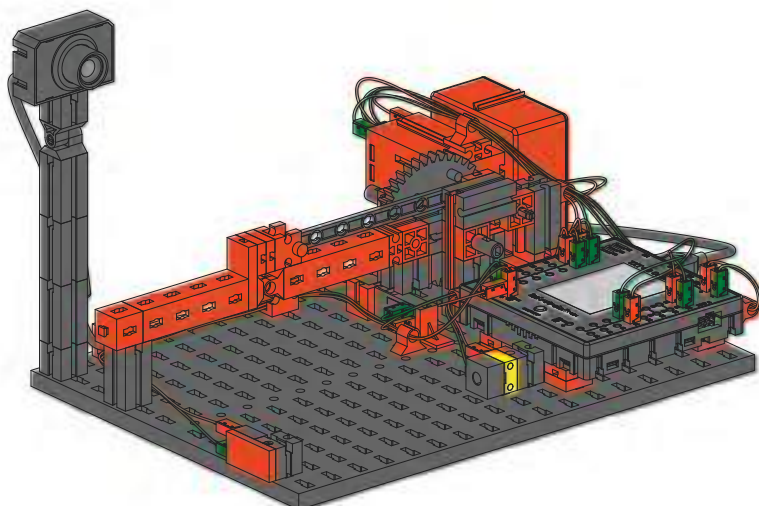

Intelligente Schranke / Intelligent barrier / Barrière intelligente / Intelligente  
barrière / Barrera inteligente / Barreira inteligente / Barriera intellintite /  
Интеллектуальный барьер / 智能屏障 ..... 8

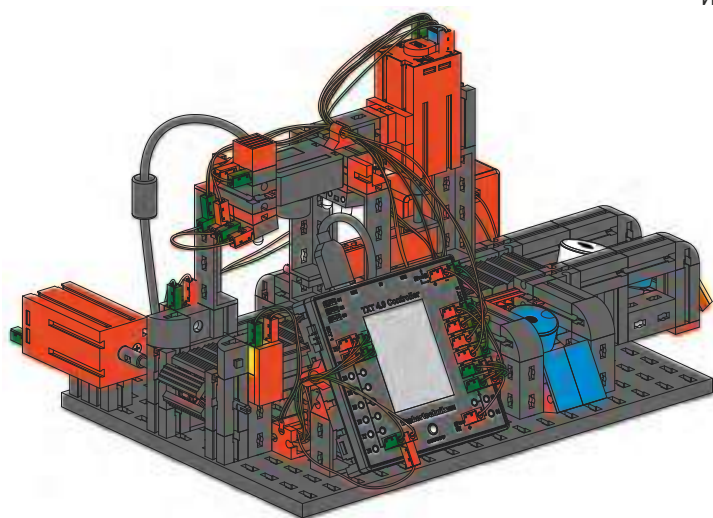



































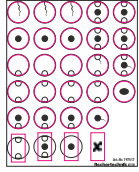

KI-Sortierstrecke / KI-Sorting line / IA-Parcours de tri / KI-Sorteerlijn /  
KI-Línea de clasificación / KI-Linha de classificação / KI-Linea di smistamento / KI-  
Сортировочная линия / KI - 分拣线 ..... 14

**Einzelteilübersicht**  
**Spare parts list**  
**Liste des pièces détachées**

**Onderdelenoverzicht**  
**Lista de piezas**  
**Resumo de peça individual**

**Singoli componenti**  
**Перечень деталей**  
**零件概览**

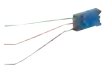
	31 011 3 x		32 880 3 x		36 921 4 x		172 542 10 x
	31 060 1 x		32 881 7 x		36 922 7 x		174 622 5 x
	31 330 2 x		35 049 3 x		36 950 1 x		174 623 5 x
	31 360 1 x		35 064 3 x		38 263 4 x		174 626 5 x
	31 762 49 x		35 077 1 x		38 266 1 x		174 627 5 x
	31 981 5 x		35 078 1 x		38 267 2 x		181 583 9 x
	31 982 13 x		36 248 98 x		38 464 2 x		181 584 10 x
	32 071 6 x		36 334 4 x		130 593 1 x		197 417 1 x
	32 330 2 x		36 532 1 x		162 135 4 x		
	32 879 17 x		36 920 17 x		168 961 1 x		



## Montagetipps Tips for assembly Tuyaux pour le montage

## Montagetips Consejos para el montaje "Dicas" para montagem

## Consigli per il montaggio Советы по сборке 装配建议

Kabel und Stecker  
Plugs and cables  
Fiches et câbles

Stekkers en cables  
Enchufes en cables  
Cabos e contatos

Cavi e connettori  
Провода и штекеры  
电缆和插头

0 3cm

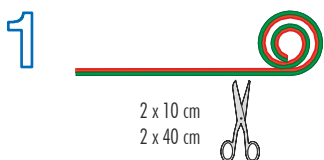

3

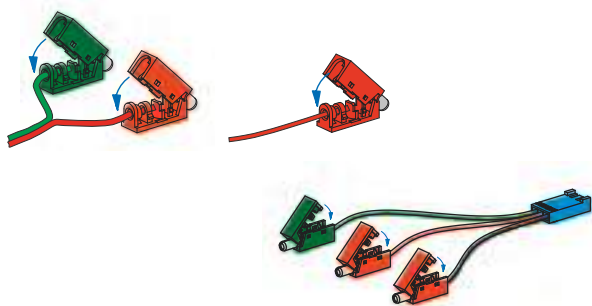

4

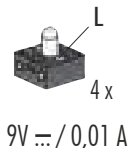
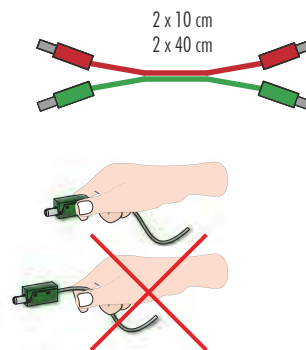

Lichtschraken LED  
Light barriers LED  
LED barrières photoélectriques  
Lichtsluis-LED  
Barreras de luz LED  
Células fotoelétricas de LED  
Barrière fotoelétriche LED  
Световой барьер LED  
光电LED

Achtung: Beim Anschluß auf richtige Polung achten.  
Caution: Make sure the terminals are connected correctly.  
Attention: lors du raccordement, veiller à ce que la polarisation soit exacte.  
Pas op: let bij het aansluiten op de juiste polariteit.  
Atención: al conectar, procurar que los polos estén correctamente colocados.  
Atenção: Por ocasião da conexão atentar para a polaridade correta.  
Attenzione: nel collegamento osservare la corretta polarità.  
Внимание: при подключении соблюдать полярность.  
注意: 连接时应注意极性正确。

## Sicherheitshinweise Safety Information Consignes de sécurité

## Veiligheidsrichtlijnen Indicaciones de seguridad Observações sobre segurança

## Informazioni per la sicurezza Указания по технике безопасности 安全指南

- Achtung! Verletzungsgefahr an Bauteilen mit funktionsbedingten scharfen Kanten und Spitzen!
- Caution! Be careful not to hurt yourself on components with sharp or pointed edges!
- Attention! Risque de blessure sur les éléments comportant des arêtes et o pointes vives indispensables au bon fonctionnement!
- Let op! U kunt zich bezeren aan bouwstenen met sherpe randen of punten!
- Atención! icuidado, no te hagas daño con los componentes con bordes afilados o puntiagudos!

- Atenção! Perigo de ferimentos em peças componentes com cantos vivos e pontas obrigatórios para o funcionamento!
- Attenzione! Pericolo di lesioni dovute a componenti con spigoli vivi e punte per motivi funzionali!
- Будьте осторожны! Об острые края деталей и и наконечники можно порезаться!
- 注意！因功能需要而带有锋利的棱边和尖角的部件可能会带来受伤危险！

- Alle Einzelteile, insbesondere bewegliche Teile sind falls notwendig zu warten und zu reinigen.
- All components, especially moving parts, should be maintained and cleaned as necessary.
- Toutes les pièces détachées et en particulier les pièces mobiles, sont, si nécessaire, à entretenir et à nettoyer.
- Alle onderdelen, vooral de bewegende delen, kunnen, indien noodzakelijk, onderhouden en gereinigd worden.
- Es necesario limpiar y mantener en buen estado todas las diferentes piezas - especialmente las piezas móviles.

- Caso necessário, todas as peças individuais, especialmente peças móveis, tem que ser submetidas à manutenção e ser limpadas.
- Se necessario, tutti i singoli componenti, soprattutto le parti mobili, si devono eventualmente sottoporre a manutenzione e pulizia.
- Все детали, особенно подвижные, требуют ухода и чистки.
- 必要时应保养和清洁所有零件，尤指运动部件。



## Sicherheitshinweise Safety Information Consignes de sécurité

## Veiligheidsrichtlijnen Indicaciones de seguridad Observações sobre segurança

## Informazioni per la sicurezza Указания по технике безопасности 安全指南

- Das Produkt darf nur mit einer der folgenden fischertechnik Energiequellen benutzt werden: Power Set oder Art.-Nr.: 35537 Accu Pack 8,4V.
- The product may only be used with one of the following fischertechnik energy sources: Power Set or Art No.: 35537 Accu Pack 8.4V. You are not allowed to use 9V NiMH accu packs in this product.
- L'utilisation de ce produit n'est permis qu'avec l'une des sources d'énergie fischertechnik suivantes: Power Set ou Art. n°: 35537 pack d'accumulateurs 8,4 volts.
- Het product mag uitsluitend met een van de volgende fischertechnik energiebronnen worden gebruikt: art.nr.: Power Set of art.nr.: 35537 accupack 8,4V
- El producto se debe utilizar únicamente con una de las siguientes fuentes de energía:

- Power Set o Art. No. 35537 paquete acumulador de 8,4V.
- O produto somente pode ser utilizado com uma das seguintes fontes de energia da fischertechnik: Power Set ou art. n°: 35537 Bloco de bateria de 8,4V.
- Questo prodotto può essere utilizzato solo con le seguenti fonti di energia fischertechnik: Power Set oppure cod. prod.: 35537 confezione batterie da 8,4V.
- Изделие можно использовать только с одним из следующих источников электропитания от fischertechnik: блок питания (арт. 505283) или улятор 8,4В (арт. 35537)
- 该商品只允许使用如下的慧鱼 (fischertechnik) 电源: 货号: 135719, 9V DC 电池盒 货号: 35537, 8.4V 电池 (Accu Pack)

- Die Modelle dürfen nur an Geräte der Schutzklasse II angeschlossen werden, die mit dem entsprechenden Symbol gekennzeichnet sind.
- Ensure that the models are connected only to equipment rated in protection category II and marked with the appropriate symbol.
- Le raccordement des maquettes est uniquement permis à des appareils dotés de la catégorie de protection II qui portent le pictogramme respectif.
- De modellen mogen alleen op apparaten uit beschermingsklasse II worden aangesloten, die zijn voorzien van het bijbehorende symbool.
- Los modelos sólo pueden ser conectados a aparatos de clase de protección II que están identificados con el símbolo correspondiente.
- Os modelos somente devem ser conectados nos aparelhos da classe de proteção II, que são identificados com o símbolo correspondente.
- I modelli devono essere collegati solo ad apparecchi della classe di protezione II, contrassegnati con il relativo simbolo.
- Модели можно подключать только к приборам класса защиты II, обозначенным соответствующим знаком.
- 这些模型只允许连接到具有防护等级 II 的装置上, 这类装置被用相应的符号进行了标识。

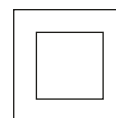

- Nicht wiederaufladbare Batterien dürfen nicht geladen werden
- Aufladbare Batterien dürfen nur von Erwachsenen geladen werden
- Aufladbare Batterien sind aus dem Batteriehalter herauszunehmen, bevor sie geladen werden.
- Batterien müssen mit der richtigen Polarität eingelegt werden.
- Leere Batterien müssen aus dem Produkt herausgenommen werden
- Die Anschlussklemmen dürfen nicht kurzgeschlossen werden.
- Verbrauchte Batterien dem Sondermüll zuführen.
- Drähte nicht in Steckdose einführen!
- Ladegerät regelmäßig auf Schäden überprüfen. Bei einem Schaden darf das Ladegerät bis zur vollständigen Reparatur nicht mehr verwendet werden.
- Alle elektrischen Bauteile (Motoren, Lampen) dürfen ausschließlich an Stromversorgungen von fischertechnik angeschlossen werden.

- Niet-oplaadbare batterijen mogen niet worden opgeladen.
- Oplaadbare batterijen mogen uitsluitend door volwassenen worden opgeladen.
- Oplaadbare batterijen moeten uit de batterijhouder worden verwijderd, voordat deze worden opgeladen.
- De batterijen moeten met de juiste polariteit worden geplaatst.
- Lege batterijen moeten uit het product worden verwijderd.
- De aansluitklemmen mogen niet worden kortgesloten.
- Afleveren gebruikte batterijen bij het klein chemisch afval (KCA).
- Geen draden in de contactdoos steken!
- Laadtoestel regelmatig controleren op schade. Bij schade mag het laadtoestel niet meer gebruikt worden tot het volledig hersteld is.
- Alle elektrische componenten (motoren, lampen) mogen uitsluitend op stroomvoorzieningen van fischertechnik worden aangesloten.

- Le batterie non ricaricabili non devono essere ricaricate
- Le batterie ricaricabili devono essere ricaricate da persone adulte
- Le batterie ricaricabili si devono estrarre dal supporto prima di ricaricarle.
- Le batterie si devono inserire rispettando la polarità.
- Togliere le batterie dal prodotto quando sono scariche
- I morsetti di allacciamento non devono essere cortocircuitati.
- Smaltire le batterie usate negli appositi contenitori per la raccolta differenziata.
- Non inserire i fili nella presa elettrica.
- Controllare periodicamente se il caricabatterie presenta dei danni. In caso di danni, il caricabatterie non deve più essere utilizzato fino alla riparazione.
- Tutti i componenti elettrici (motori, lampadine) devono essere collegati esclusivamente ad alimentatori fischertechnik.

- Do not attempt to charge NON-rechargeable batteries.
- Rechargeable batteries are only to be charged by adults.
- Take rechargeable batteries out of the battery tray before charging them.
- Insert batteries with the correct polarity.
- Remove dead batteries from the product.
- Do not short circuit the connecting terminals!
- Discard spent dry cells at special waste disposal centre.
- Do not insert the wires into an outlet!
- Regularly inspect battery charger for damage. If the battery charger has been damaged, it should not be used further until fully repaired.
- No electrical components (motors, lamps) are to be connected to any other power supply than that provided by fischertechnik.

- Las pilas no recargables no pueden ser cargadas
- Las pilas recargables sólo pueden ser cargadas por un adulto
- Las pilas recargables deben ser extraídas del compartimento de pilas antes de que sean cargadas.
- Las pilas deben ser colocadas con la polaridad correcta.
- Las pilas descargadas deben ser extraídas del producto
- Los bornes de conexión no pueden ser puestos en cortocircuito.
- Retirar las baterías viejas, desechándolas en un depósito de basuras especiales.
- No introducir hilos en la toma de corriente!
- Comprobar con regularidad si el cargador presenta daños. En caso de presentar daños, el cargador no debe volver a ser utilizado hasta que esté completamente reparado.
- Todos los componentes eléctricos (motores, luces) deben conectarse a la alimentación de corriente de la técnica Fischer exclusivamente.

- Не пытайтесь заряжать неперезаряжаемые батарейки.
- Зарядку перезаряжаемых аккумуляторов разрешается выполнять только взрослым.
- Перед зарядкой перезаряжаемых аккумуляторов извлеките их из аккумуляторного отсека.
- При установке аккумуляторов на место соблюдайте полярность.
- Разряженные батарейки необходимо извлечь из игрушки.
- Не замыкайте накоротко соединительные клеммы.
- Использованные батареи утилизировать как спецотходы.
- Не вставляйте в розетку провода!
- Регулярно проверяйте зарядное устройство на отсутствие повреждений. При наличии повреждений использовать зарядное устройство до выполнения его полного ремонта не разрешается.
- Все электрические детали (электромоторы, лампочки.) можно подключать только к источникам электропитания от fischertechnik.

- Il est interdit de recharger des piles qui ne sont pas des accumulateurs
- Le chargement des accumulateurs doit toujours se faire par des adultes
- Retirer les accumulateurs du support de pile avant de les recharger.
- Veiller à la polarité correcte lors de la mise en place des piles.
- Retirer impérativement les piles ou accumulateurs vides du produit.
- Il est interdit de court-circuiter les bornes de raccordement.
- Jeter les piles usagées dans un conteneur spécial réservé à cet effet.
- Ne pas introduire les fils dans une prise !
- Contrôlez régulièrement le chargeur en vue d'éventuelles détériorations
- En cas de détérioration, il est interdit d'utiliser le chargeur jusqu'à ce qu'il ait été intégralement réparé
- Tous les composants électriques (moteurs, lampes) ne doivent être branchés aux alimentations électriques uniquement que par la société Fischertechnik.

- Pilhas não recarregáveis não devem ser novamente carregadas.
- Pilhas recarregáveis somente devem ser recarregadas por adultos.
- Pilhas recarregáveis devem ser retiradas do compartimento de pilhas antes de serem carregadas.
- As pilhas devem ser colocadas com a polaridade correta.
- As pilhas descarregadas devem ser retiradas do produto.
- Os terminais de conexão não devem ser curto-circuitados.
- Eliminar as baterias esgotadas como desperdício perigoso
- Nunca introduzir fios na tomada!
- Verificar regularmente se o carregador apresenta danos. Em caso de dano, o carregador não deverá ser utilizado enquanto não estiver plenamente consertado.
- Todas as peças componentes elétricas (motores, lâmpadas) só podem ser exclusivamente conectadas em abastecimentos de corrente da Fischertechnik.

- 不得给非充电电池充电
- 只允许由成年人给充电电池充电
- 在充电前必须将充电电池从电池夹中取出。
- 必须按照正负极正确放入电池。
- 未充电的电池必须从模型中取出
- 接线柱不允许被短路。
- 用完了的电池应作为特种垃圾处理。
- 禁止将金属丝插入插座!
- 经常检查充电器是否有损坏情况。如果充电器有损, 直到完全修好为止不可以再使用。
- 电气元件 (传感器、电机、灯泡) 必须连接到fischertechnik的电源上



Hinweise zum Umweltschutz / Instructions for Environmental Protection / Remarques de protection de l'environnement / Bescherming van het milieu / Notas con respecto a la protección del medio ambiente / Instruções para a proteção do meio ambiente / Indicazioni sulla tutela ambientale / Указания по охране окружающей среды / 有关环保的提示 :

www.fischertechnik.de/environment

# Teachable Machine

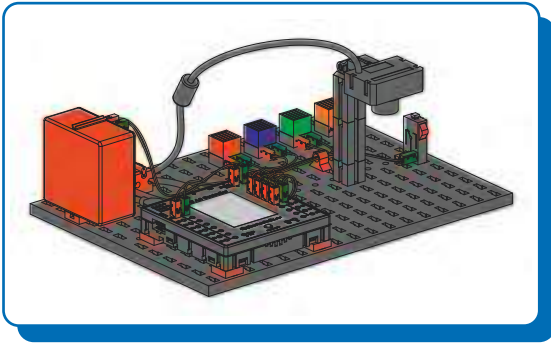

**1**

- 1x red 1x3 Technic brick
- 1x red 1x2 Technic brick with a hole
- 1x red 1x2 Technic brick with a hole and a notch
- 1x grey 1x2 Technic brick with a hole
- 2x red 1x2 Technic brick with a hole and a notch
- 4x grey Technic pins (labeled 'L')

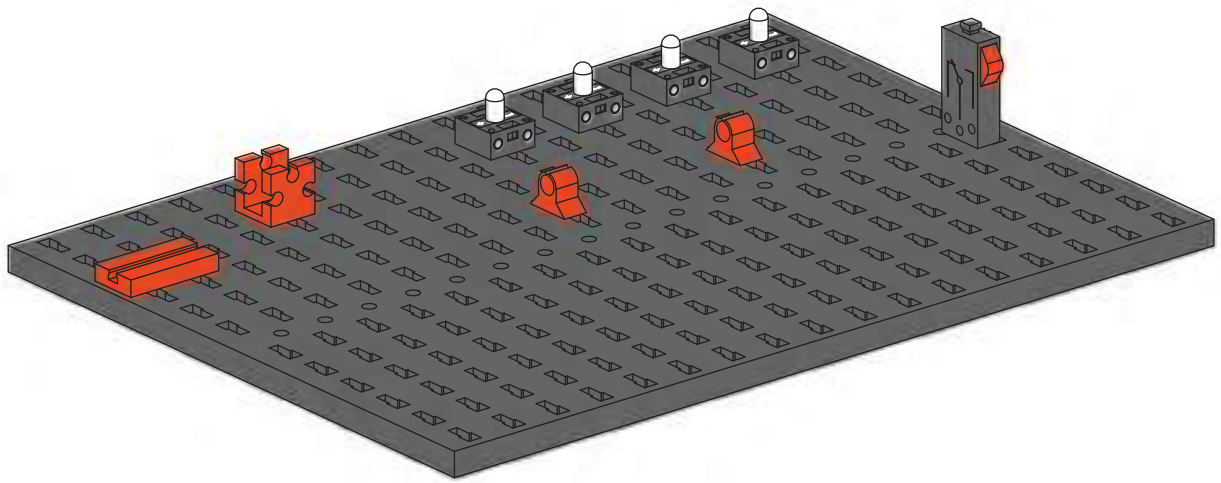

**2**

- 2x grey 1x2 Technic bricks
- 2x grey 1x2 Technic bricks
- 1x grey 1x2 Technic brick with a hole
- 1x red 1x2 Technic brick with a hole and a notch
- 1x grey 1x2 Technic brick with a hole
- 1x orange 1x2 Technic brick with a hole
- 1x green 1x2 Technic brick with a hole
- 1x blue 1x2 Technic brick with a hole
- 1x red 1x2 Technic brick with a hole and a notch

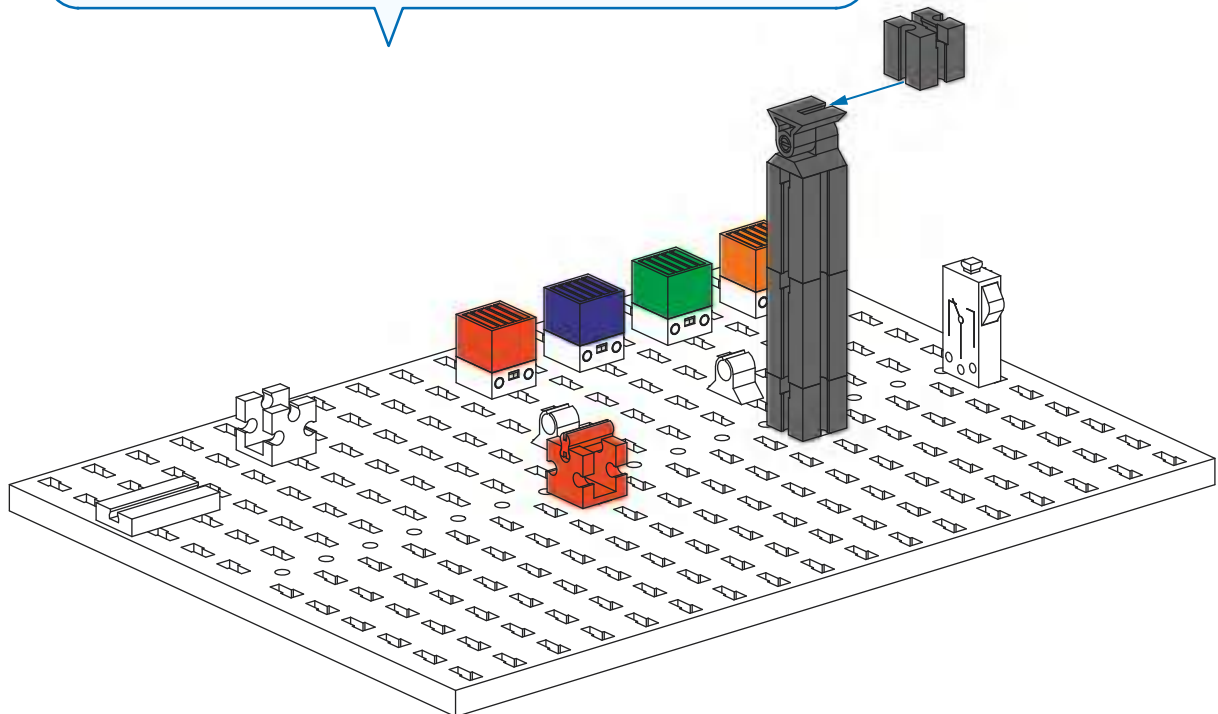

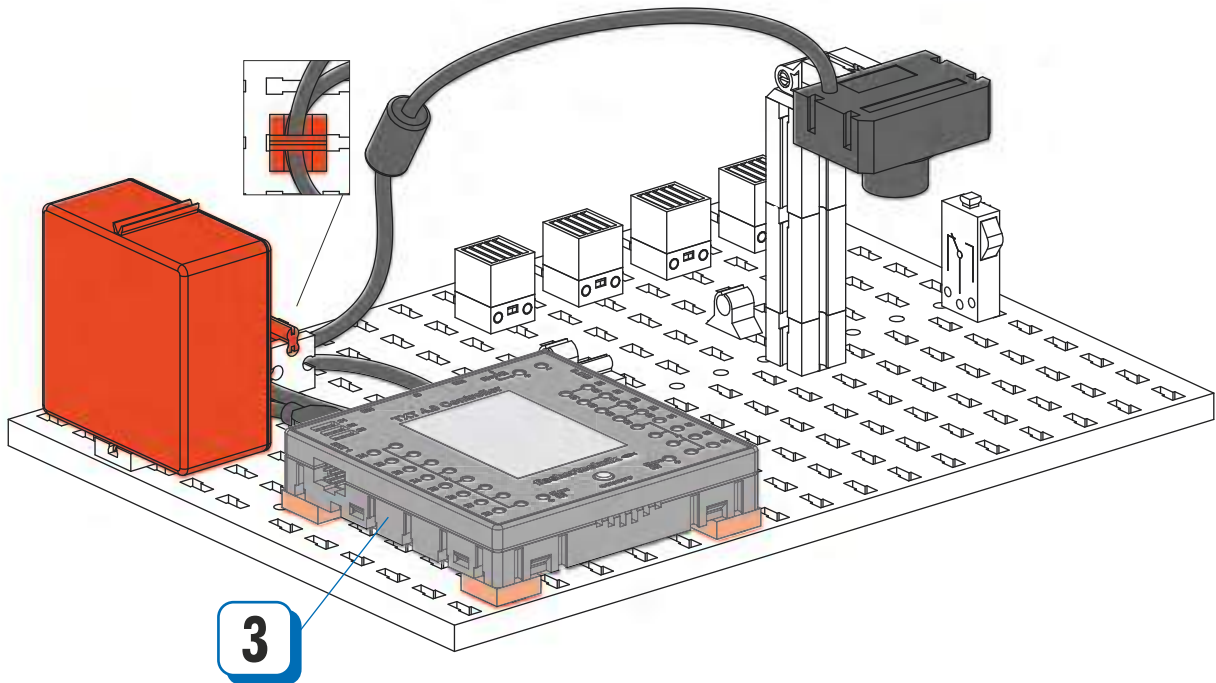
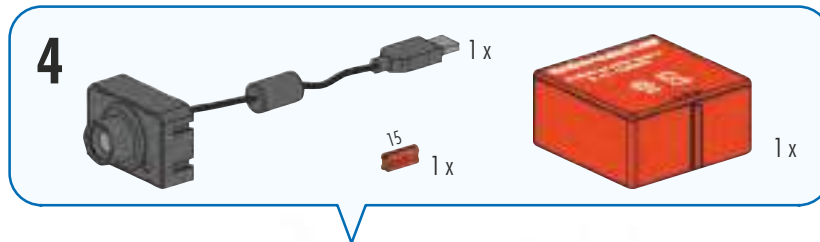
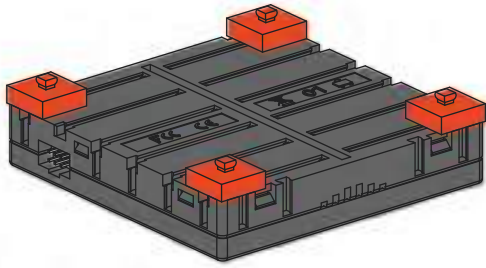



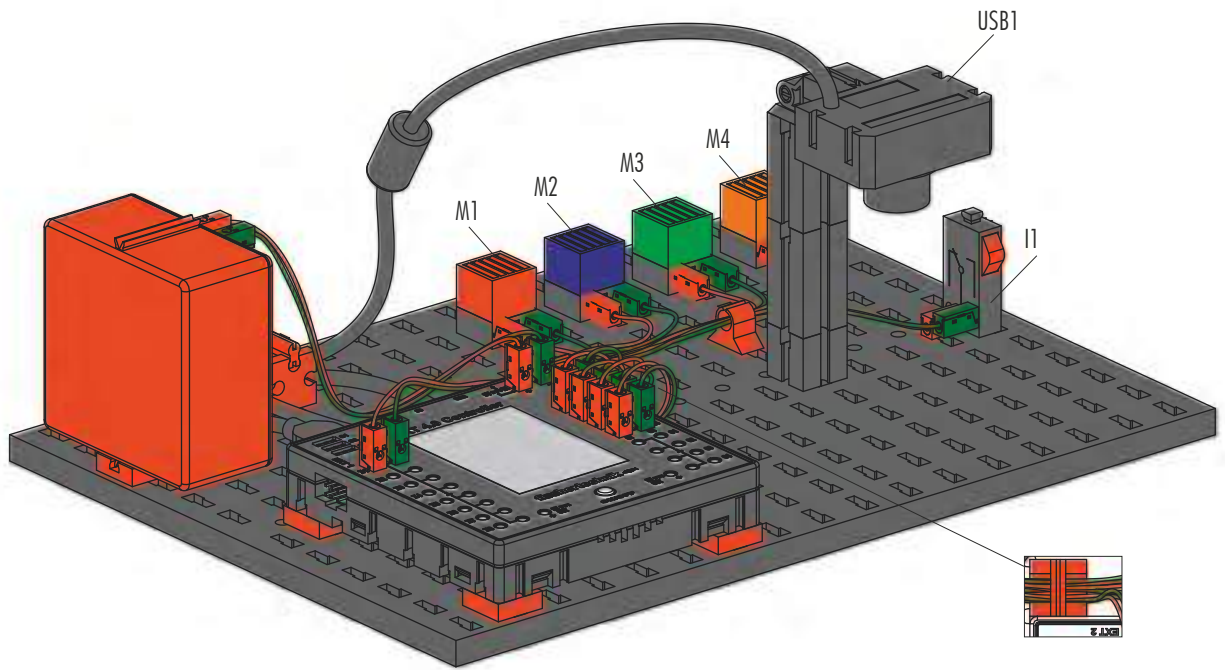

Schaltplan  
Circuit diagram  
Plan électrique

Schakelschema  
Diagrama de circuitos  
Plano elétrico de ligação

Schema elettrico  
Схема подключения  
电路图

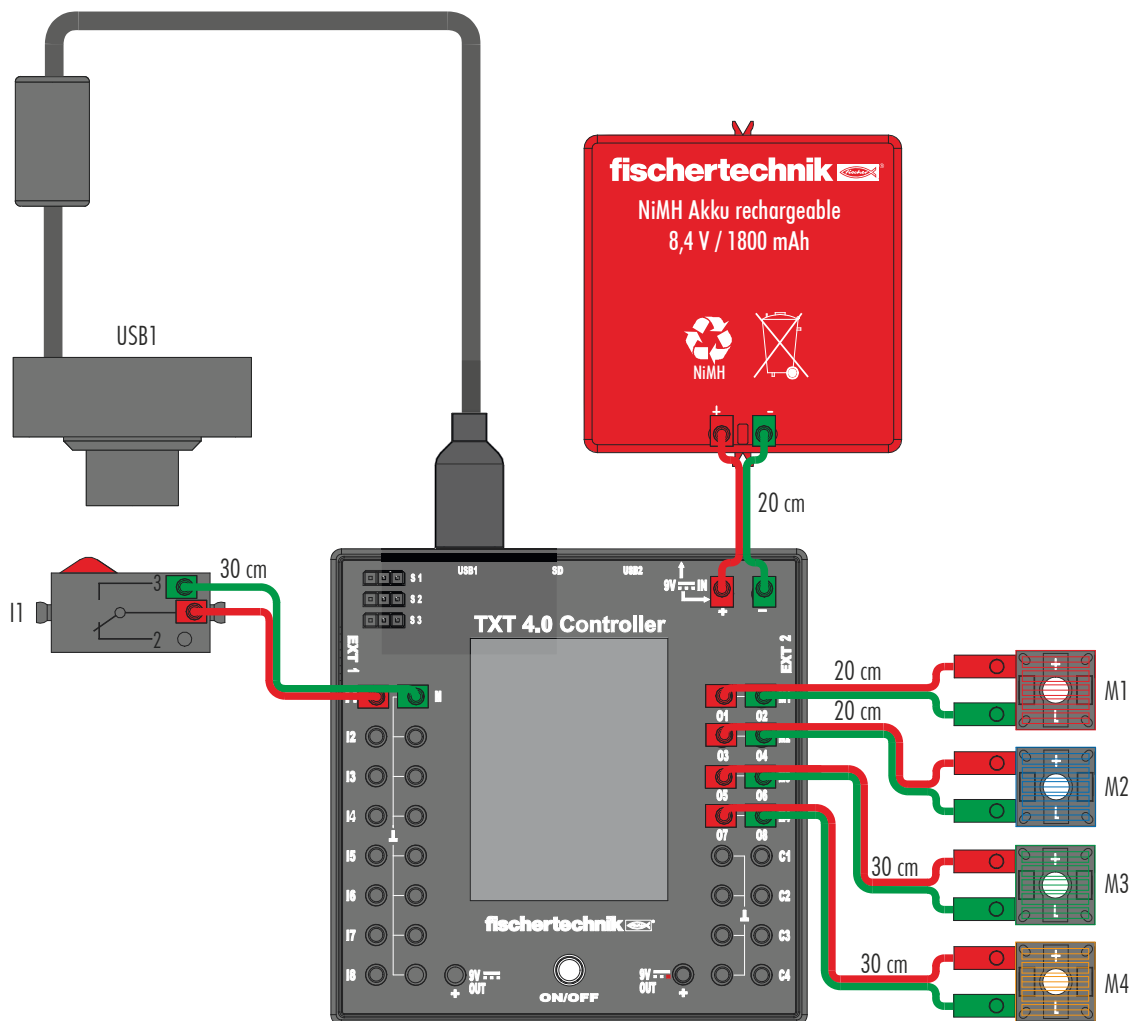

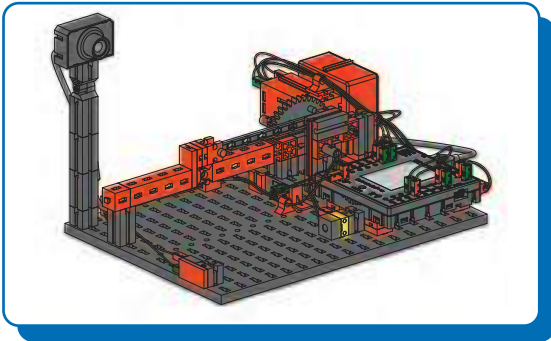

Intelligente Schranke  
Intelligent barrier  
Barrière intelligente

Intelligente barrièrre  
Barrera inteligente  
Barreira inteligente

Barriera intelligente  
Интеллектуальный барьер  
智能屏障

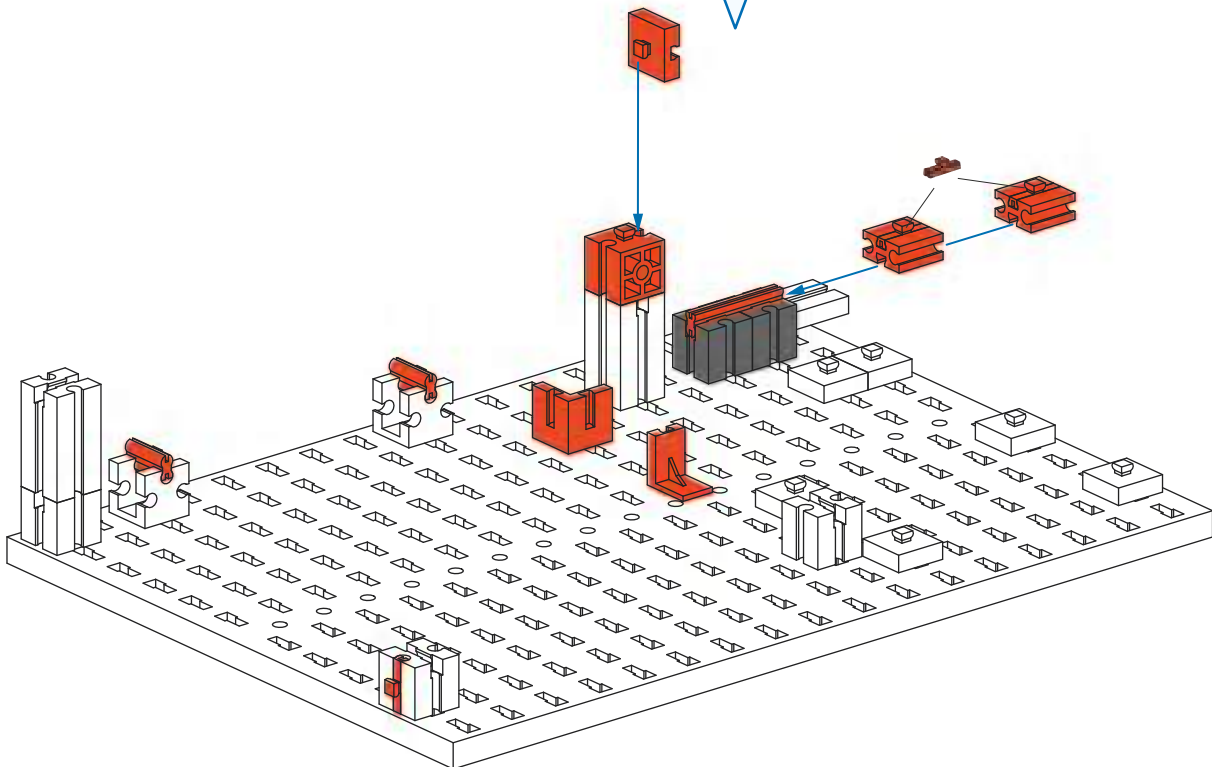
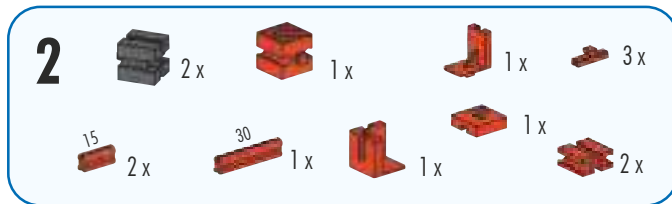
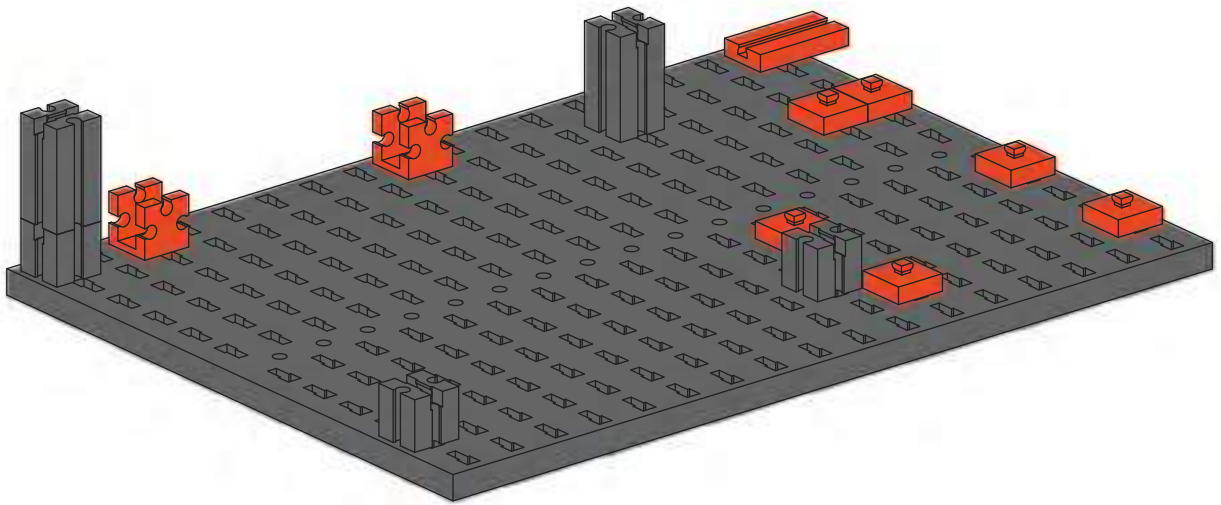
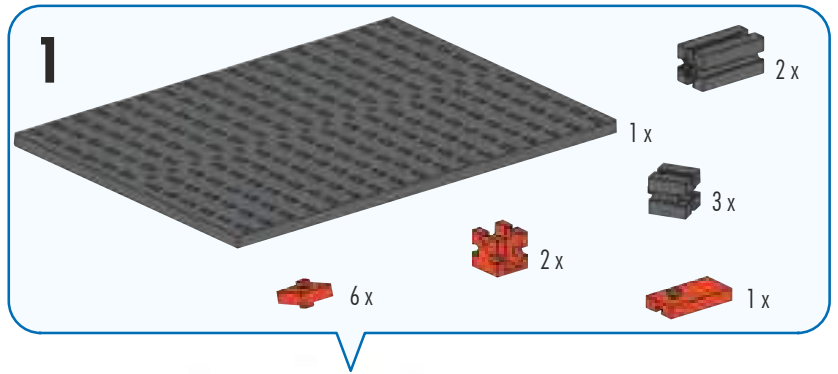





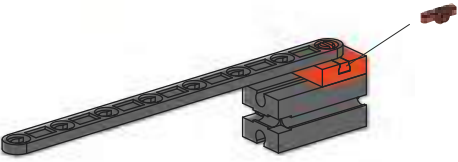
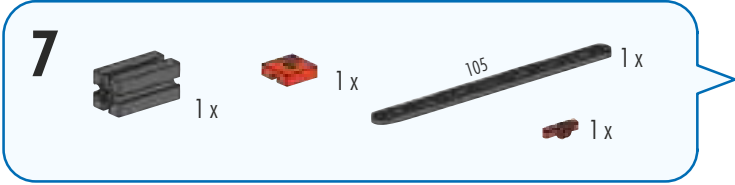
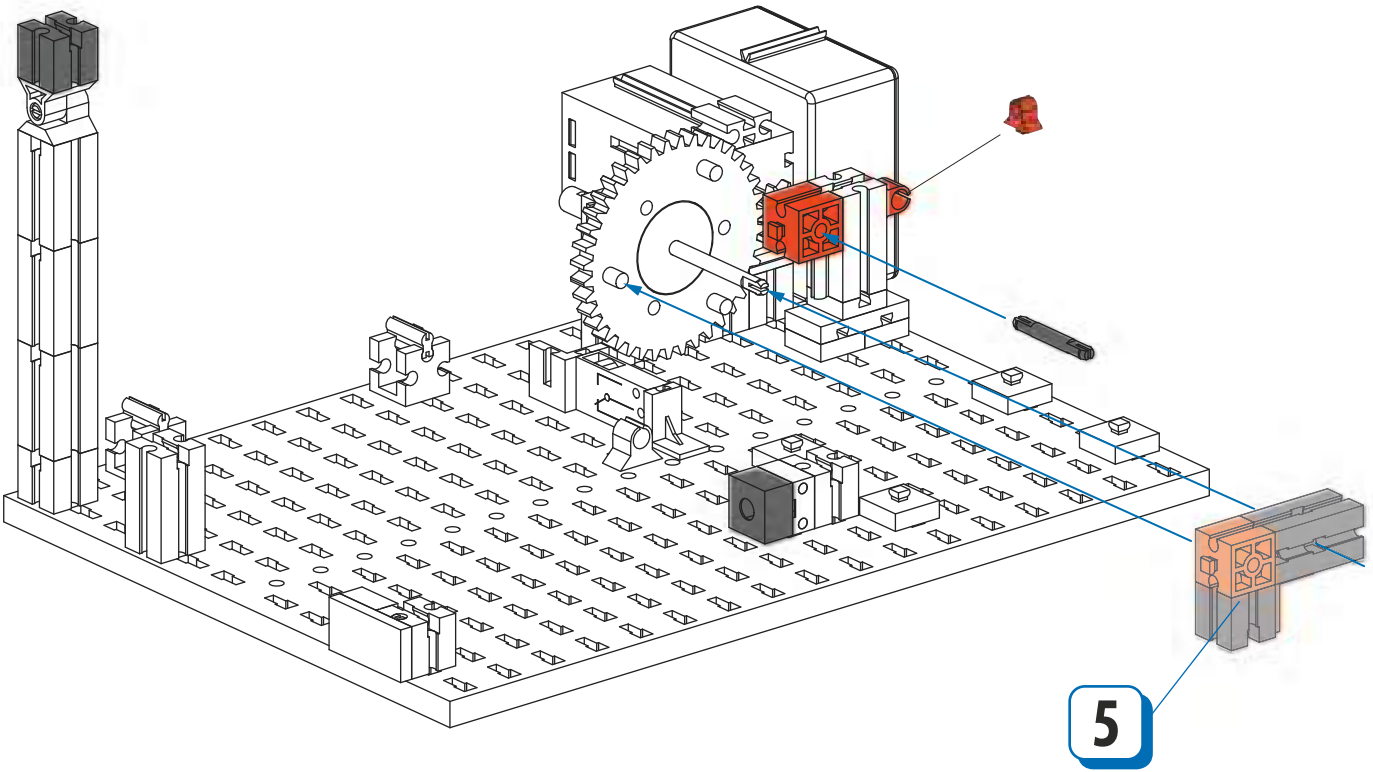
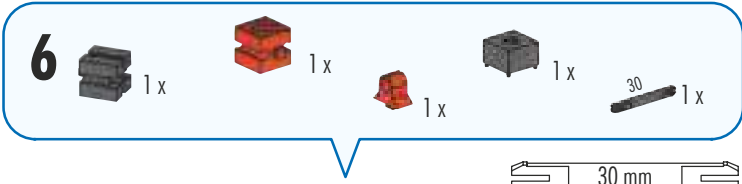
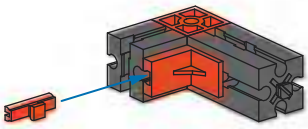
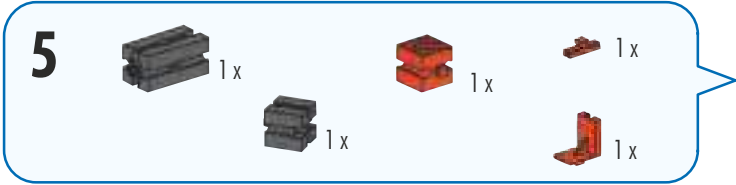

- 8** 1x 1x 1x 1x 1x 1x 1x
- 1x Red 1x3 Technic Beam
  - 1x Red 1x2 Technic Beam
  - 1x Red 1x2 Technic Beam with Pin
  - 1x Red 1x2 Technic Beam with Pin
  - 1x Black 1x3 Technic Beam
  - 1x Red 1x2 Technic Beam with Pin
  - 1x Black Pin

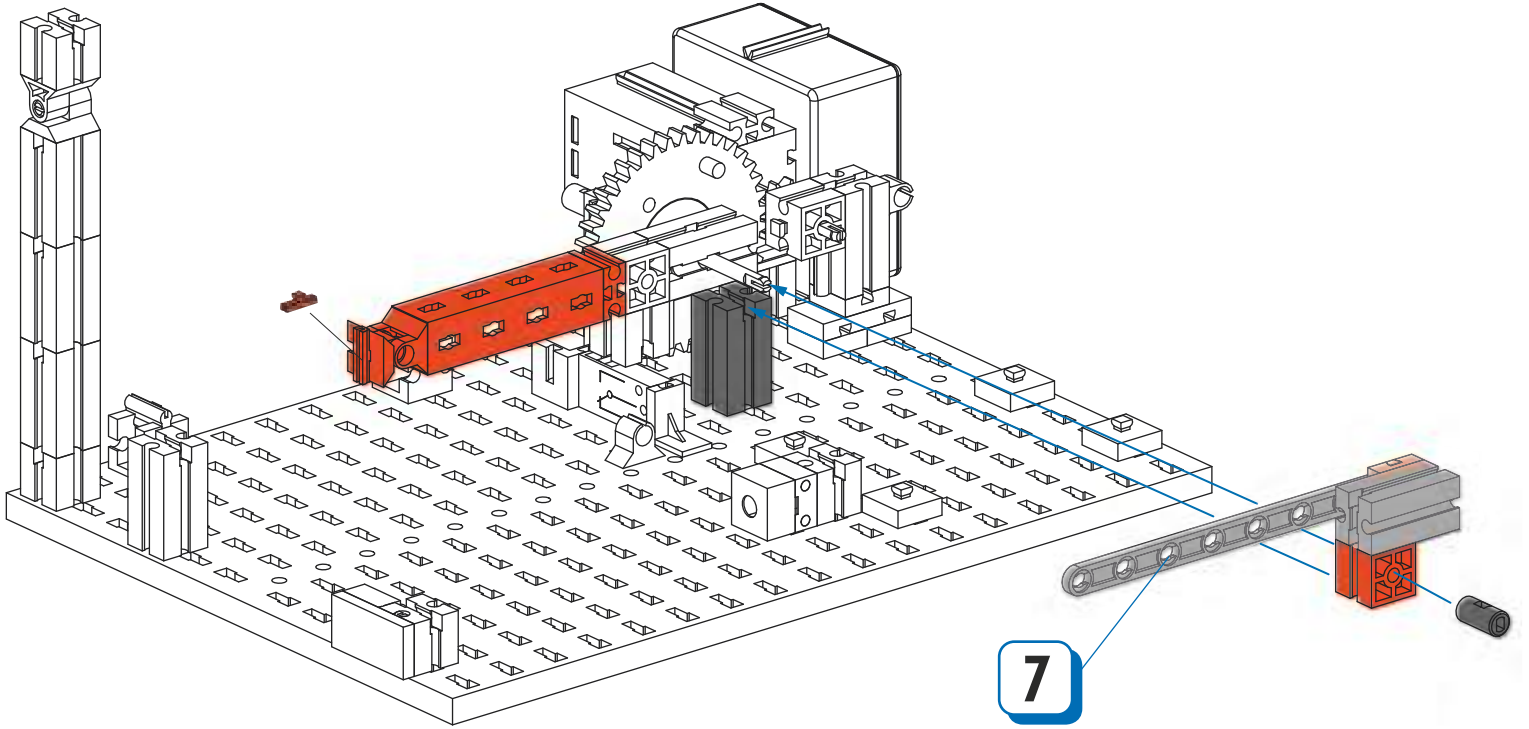

- 9** 1x 1x 2x 1x 1x 1x 1x
- 1x Red 1x3 Technic Beam
  - 1x Red 1x2 Technic Beam with Pin
  - 2x Red 1x2 Technic Beam
  - 1x Red 1x2 Technic Beam with Pin
  - 1x Red 1x2 Technic Beam with Pin
  - 1x Red 1x3 Technic Beam with Pin
  - 1x Red 1x3 Technic Beam with Pin

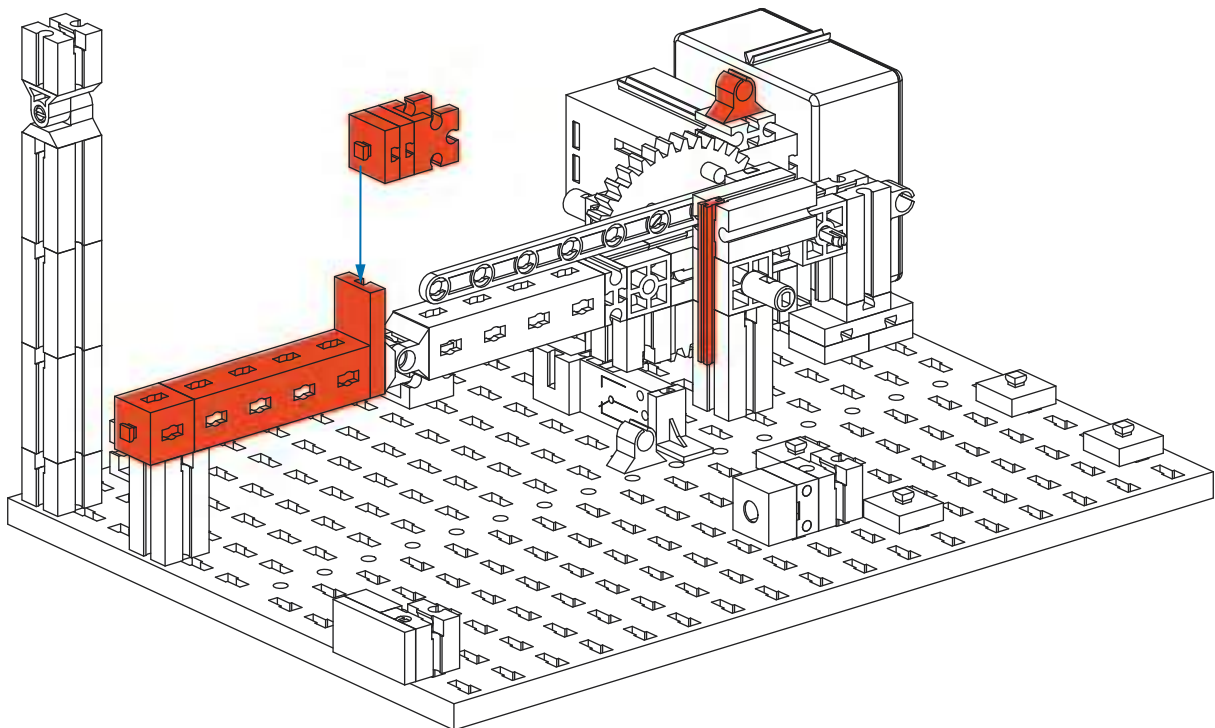

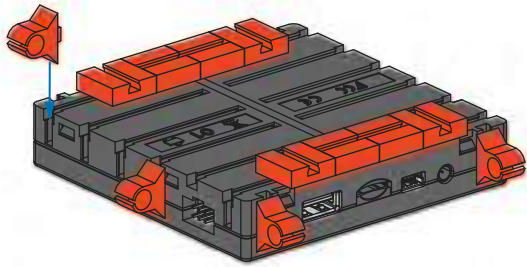

**10**

1 x

8 x

4 x

**11**

1 x

1 x

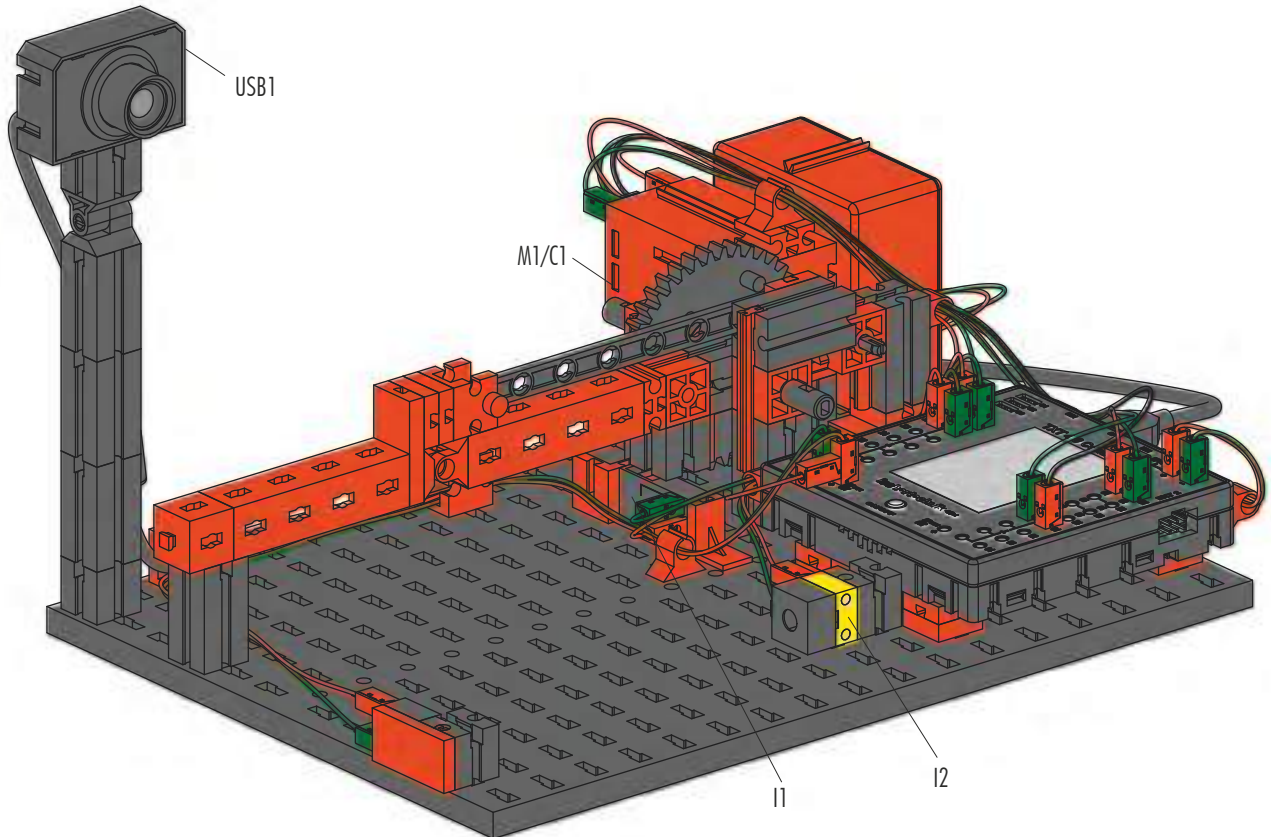
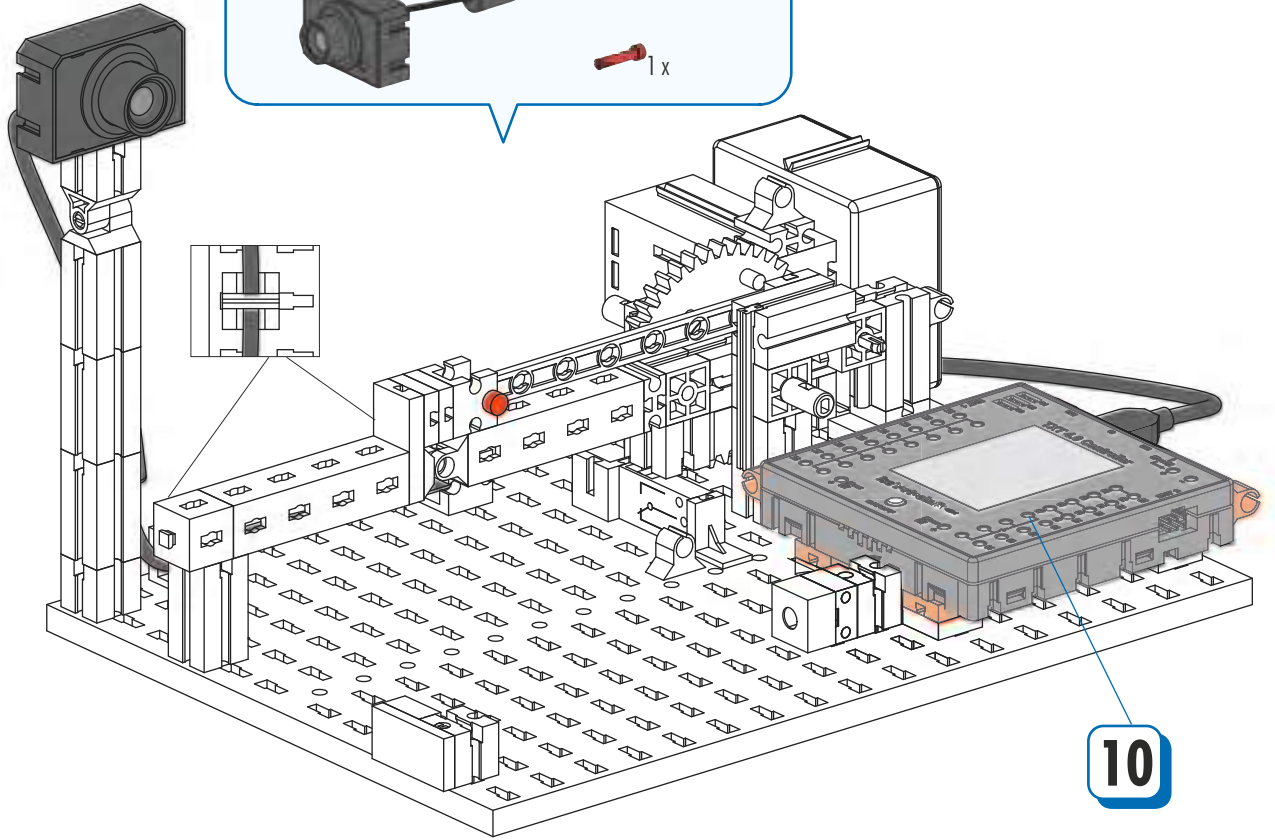



Schaltplan  
Circuit diagram  
Plan électrique

Schakelschema  
Diagrama de circuitos  
Plano elétrico de ligação

Schema elettrico  
Схема подключения  
电路图

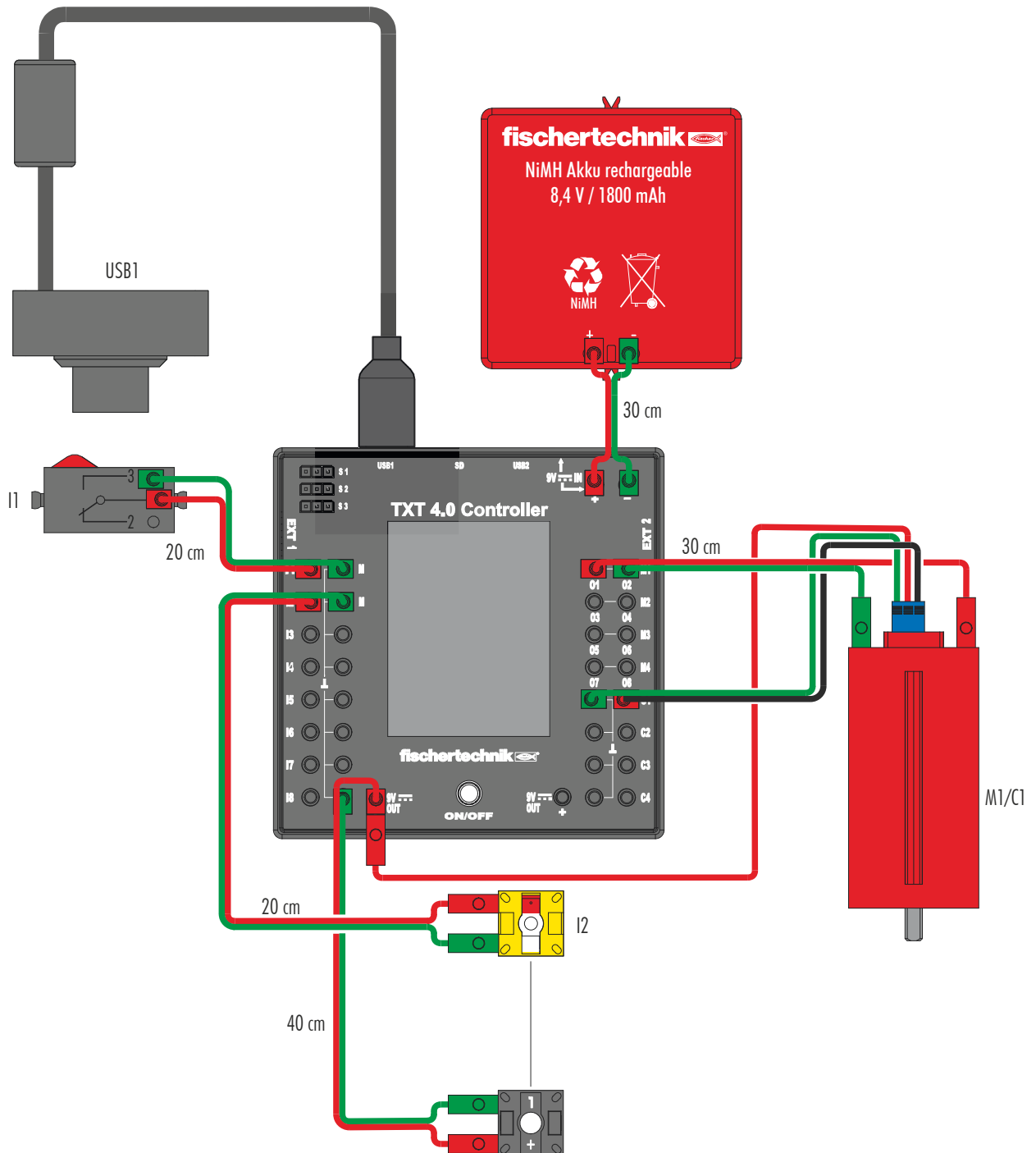



4

30 1x 45 1x 1x 2x 2x

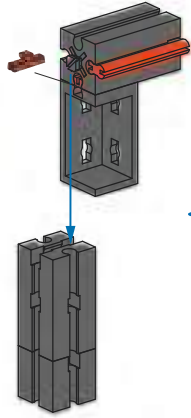
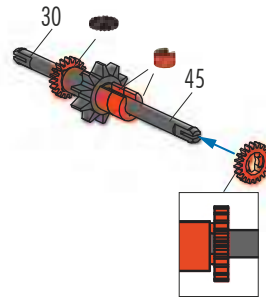
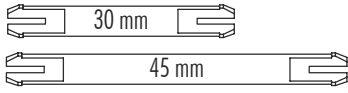

5

1x 1x 1x 1x 1x 30 1x

6

2x 2x 2x 4x 4x 15° 2x

4

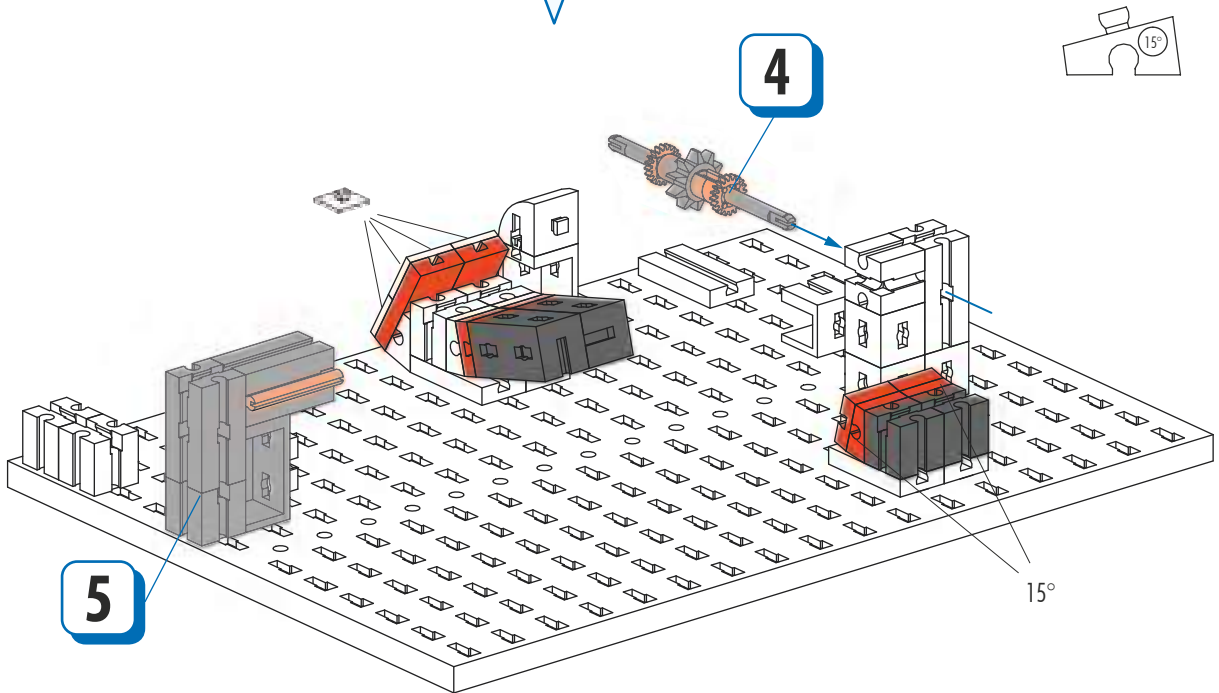

7

45 2x 1x 2x 2x

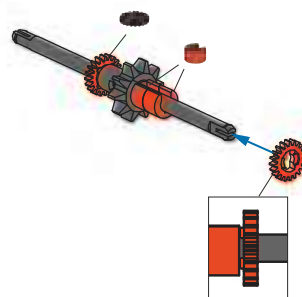



8

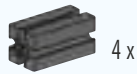

4 x

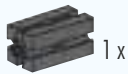

1 x



2 x



1 x



2 x



2 x



3 x



1 x



1 x

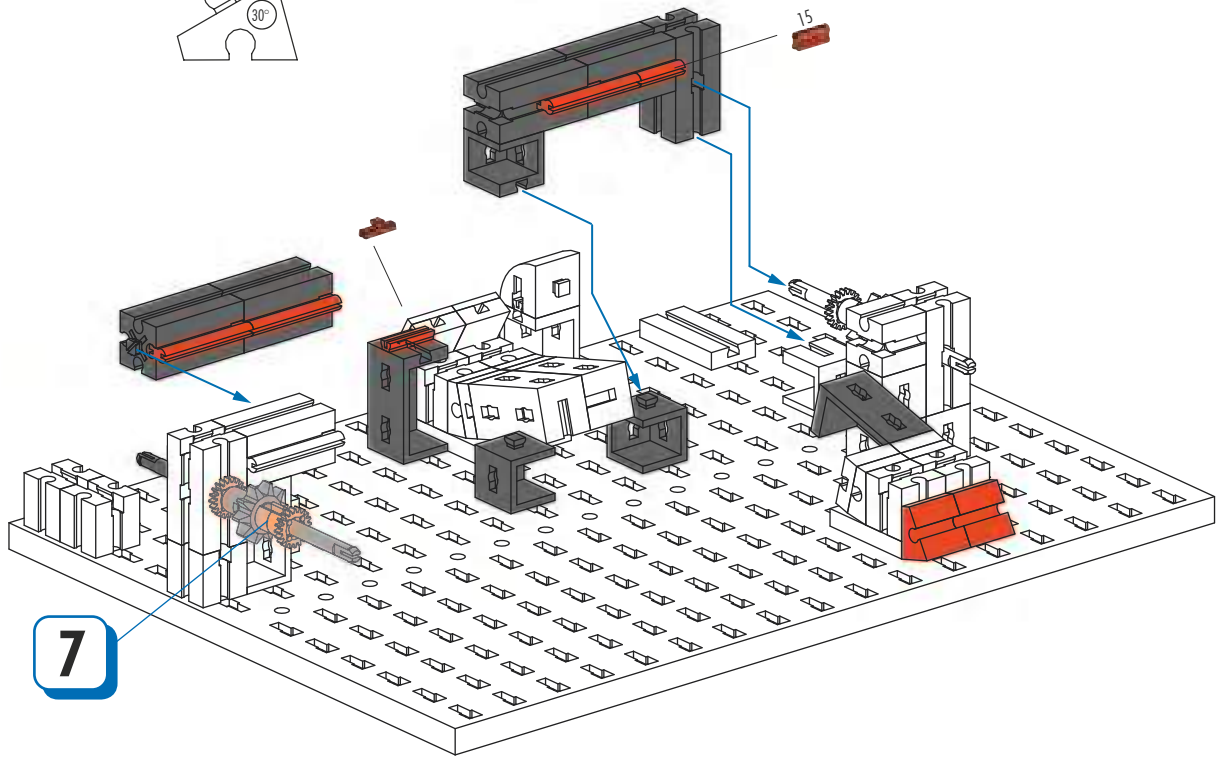
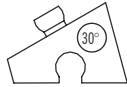

7

9



1 x



1 x



1 x



1 x



2 x



2 x

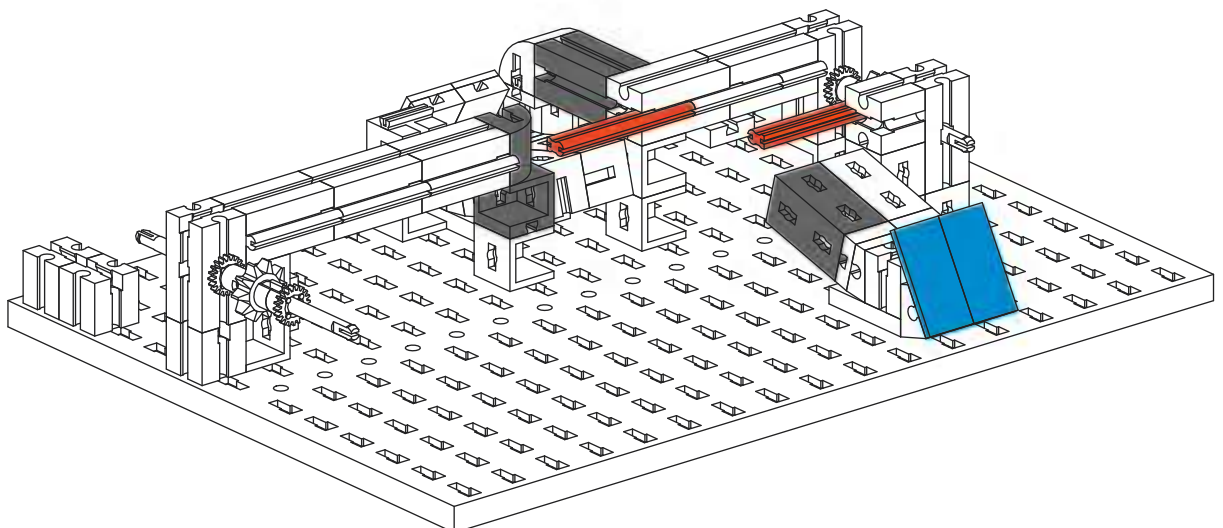

**10**

- 1x (black 1x3 Technic axle)
- 2x (black 1x2 Technic axle)
- 1x (black 1x3 Technic axle)
- 1x (red 1x2 Technic axle)
- 1x (red 1x2 Technic axle)

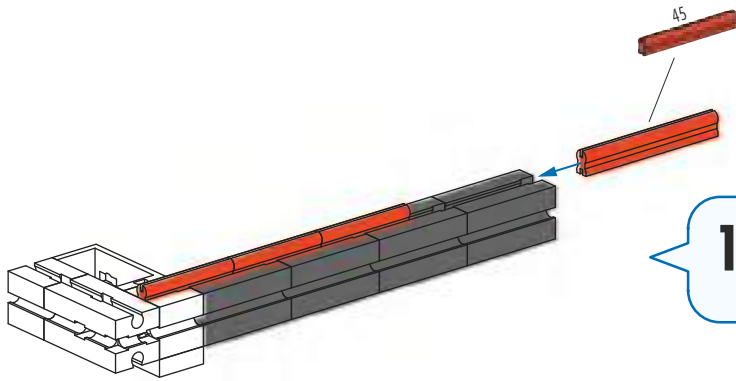
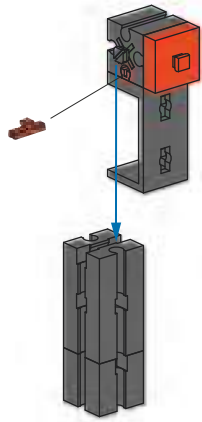

**11**

- 4x (black 1x3 Technic axle)
- 3x (red 30 Technic axle)
- 1x (red 45 Technic axle)

**12**

- 1x (black 1x3 Technic axle)
- 1x (black 1x3 Technic axle)
- 1x (black 1x3 Technic axle)
- 1x (black 1x3 Technic axle)
- 1x (black 1x3 Technic axle)
- 1x (red 15 Technic axle)
- 1x (red 1x2 Technic axle)

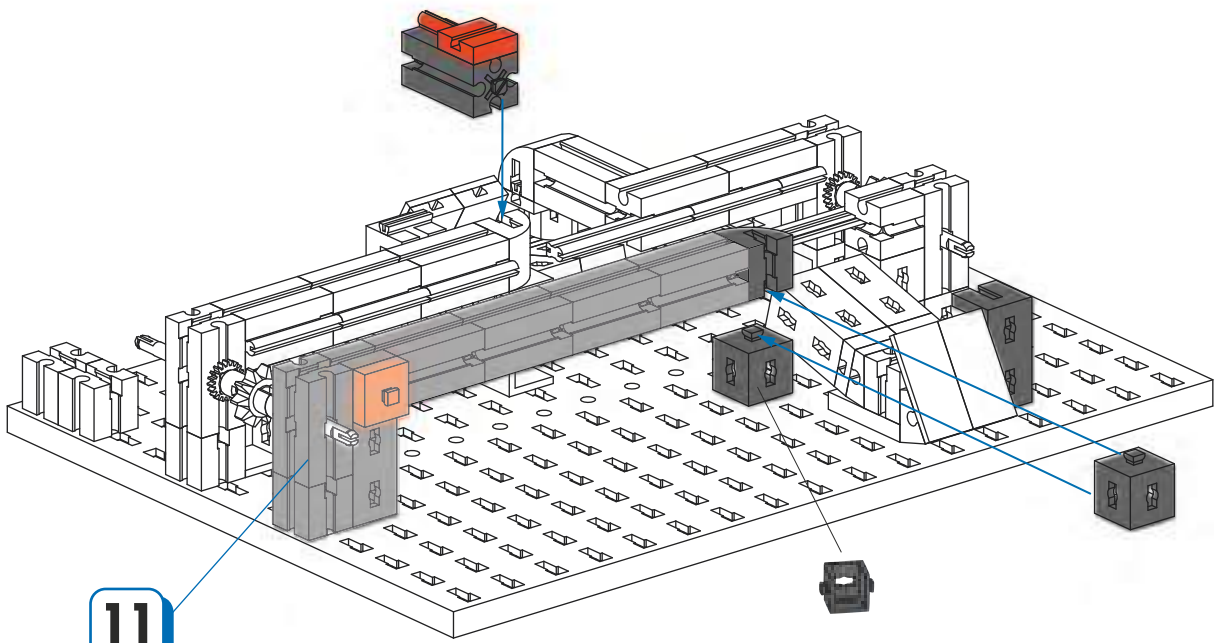

**11**

13

49 x 98 x

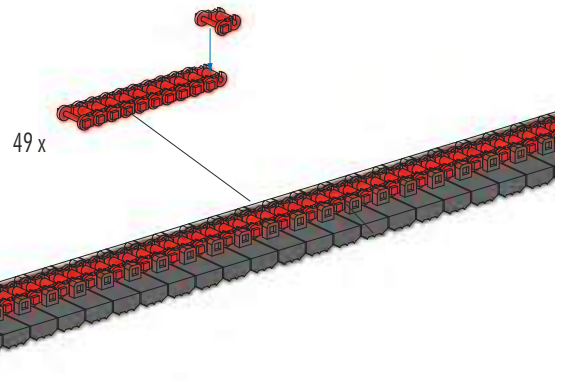

14

1 x 2 x 1 x 1 x 15 1 x



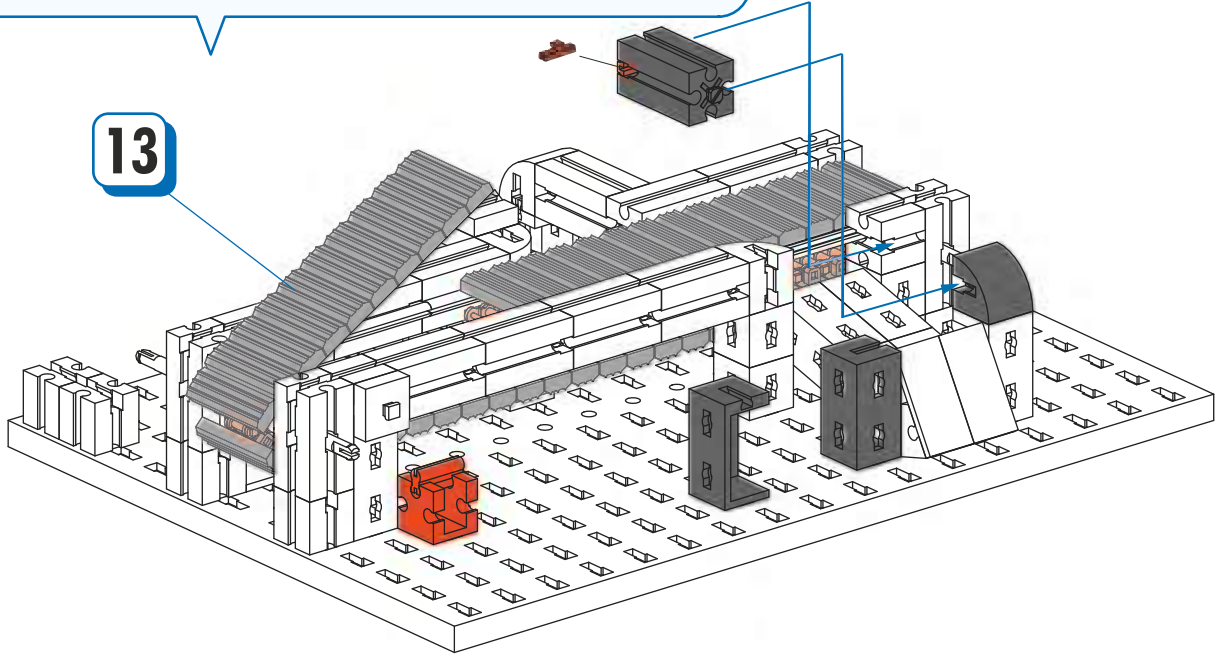

13



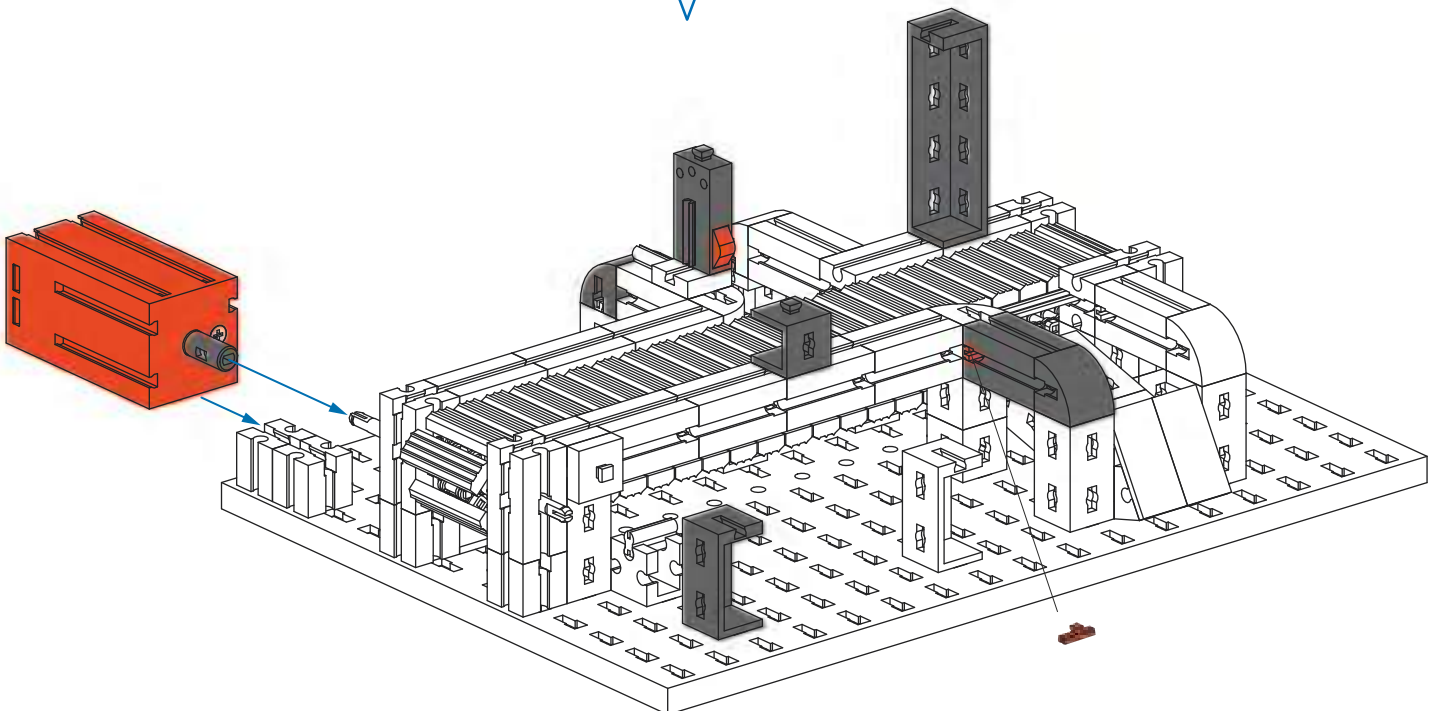

15



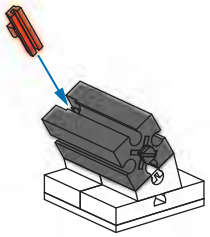
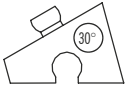
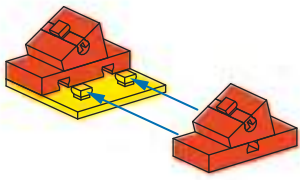

1 x 1 x 1 x 1 x 1 x 1 x 1 x 1 x





**16**  2x  1x  2x  2x





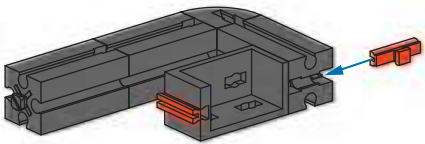
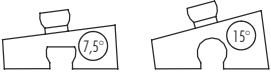
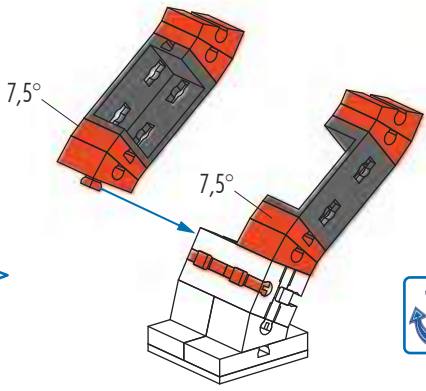

**17**  1x  1x

**18**  2x  2x  2x  6x



**19**  3x  1x  1x  2x

**20**  3x  1x  1x  2x

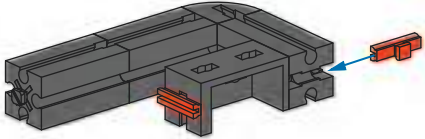



21

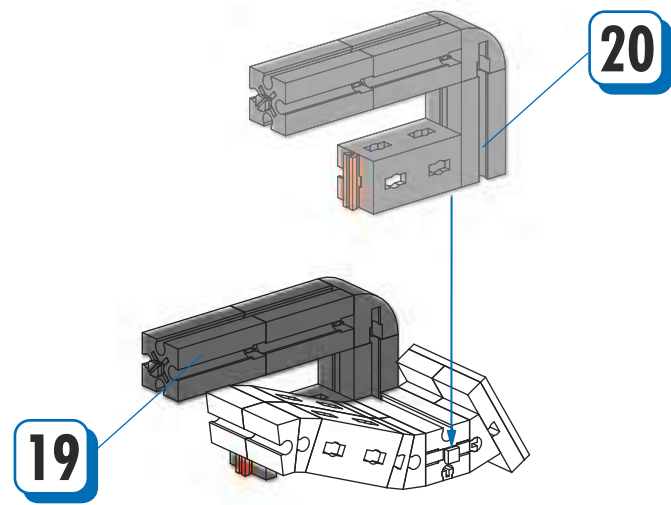

22

1x

2x

2x

This block lists the parts for step 22: one red rectangular component, two black components, and two red components. Each part is accompanied by its quantity.

21

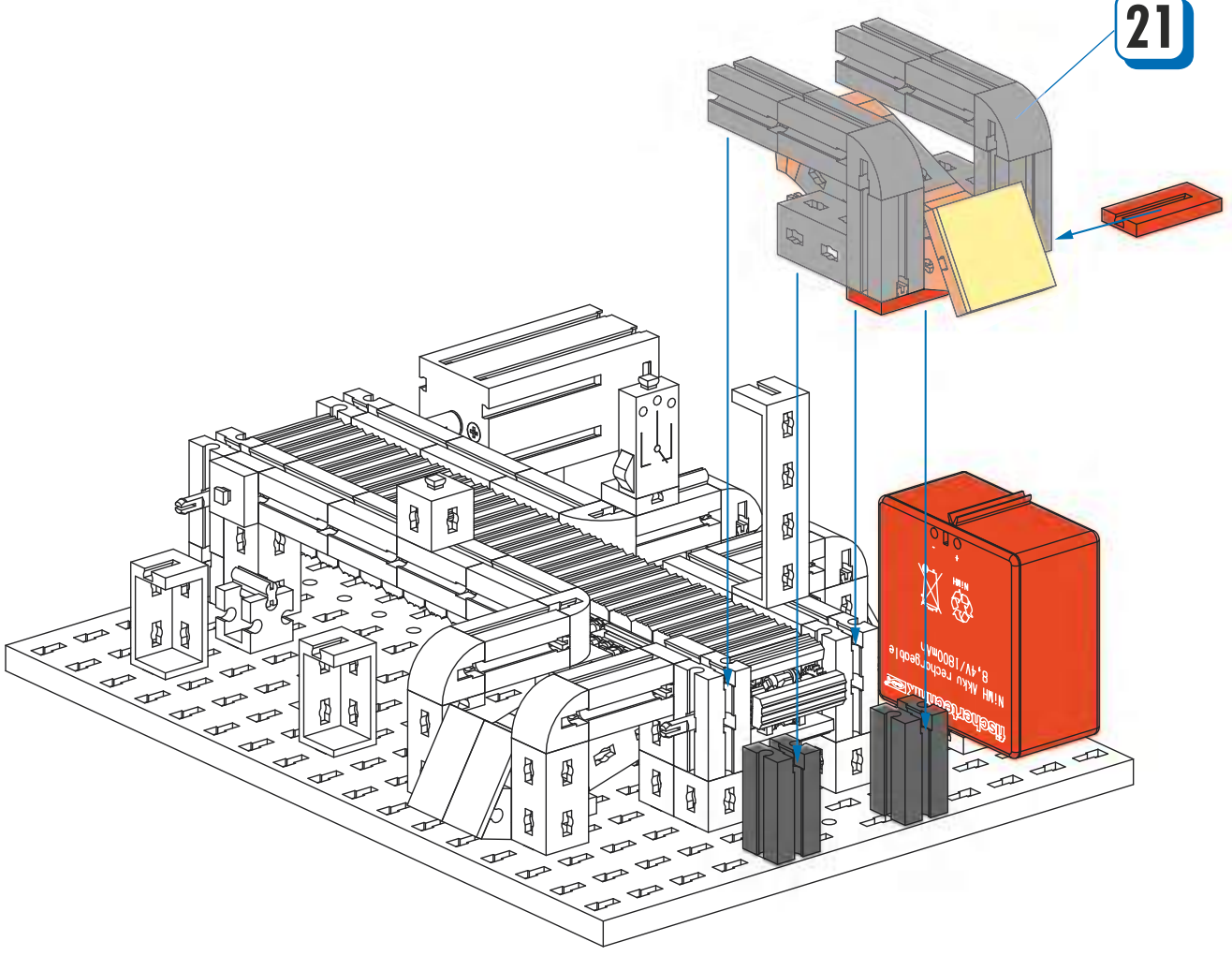

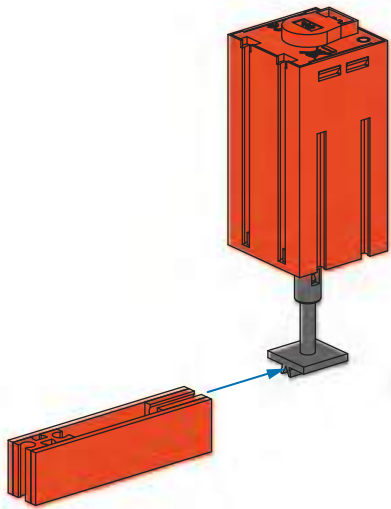

**23**

- 1x Red 1x4 Technic Beam
- 2x Red 1x4 Technic Beam
- 1x Grey Pin
- 2x Red 1x2 Technic Connector
- 1x Grey Technic Pin

**24**

- 1x Grey Technic Pin
- 2x Grey Technic Pin
- 1x Grey 1x4 Technic Beam
- 1x Red 1x2 Technic Connector
- 1x Grey Technic Pin

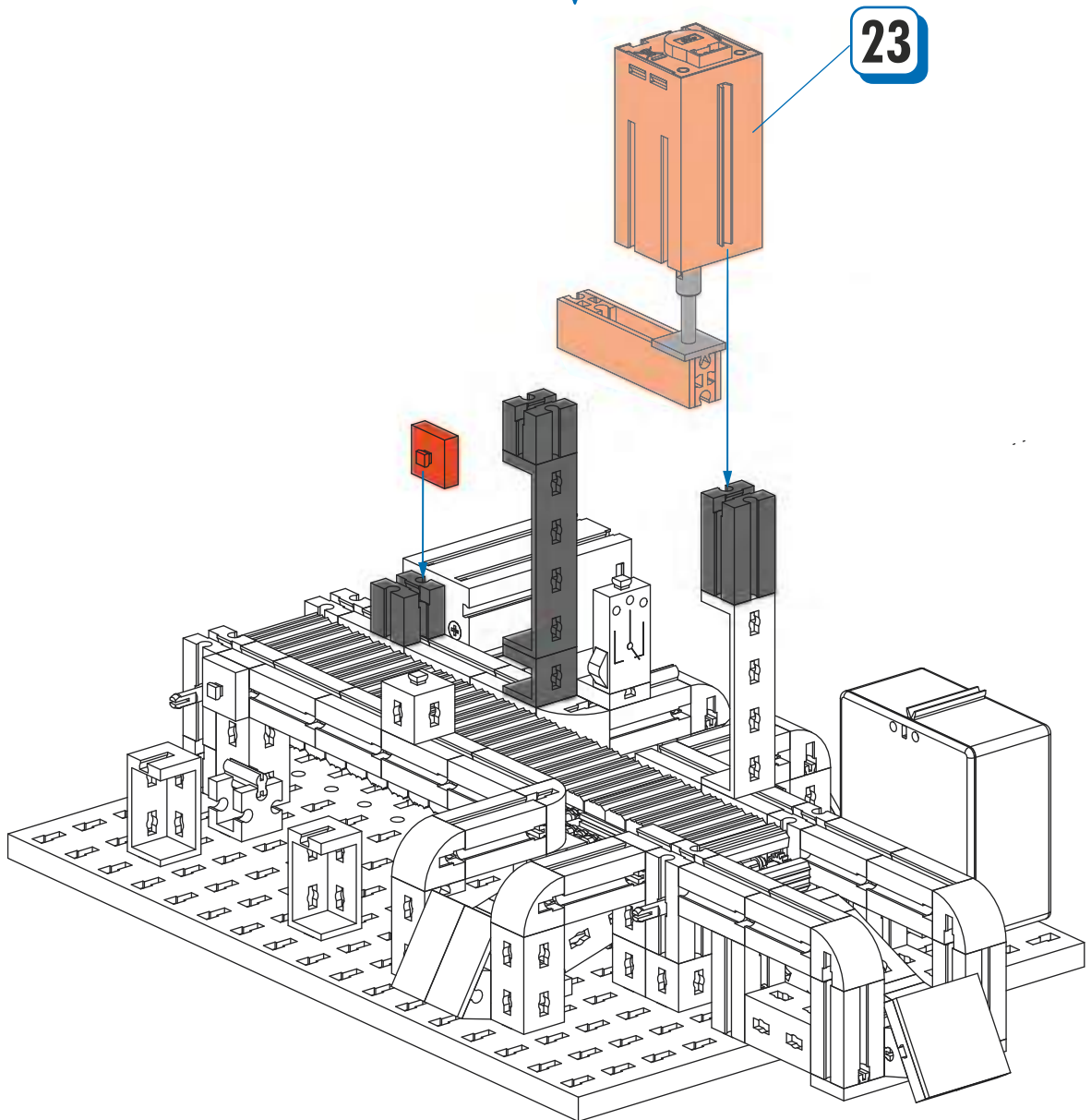

25

- 1x [Black 1x3 Technic Beam]
- 1x [Black 1x3 Technic Beam]
- 4x [Red 1x1 Technic Pin]
- 1x [Red 1x2 Technic Pin]
- 1x [Red 1x2 Technic Pin]
- 1x [Red 1x2 Technic Pin]
- 2x [Red 1x2 Technic Pin, 7.5°]
- 2x [Black L-shaped Technic Pin]
- 1x [Red 1x3 Technic Beam]
- 1x [Red 1x5 Technic Beam]

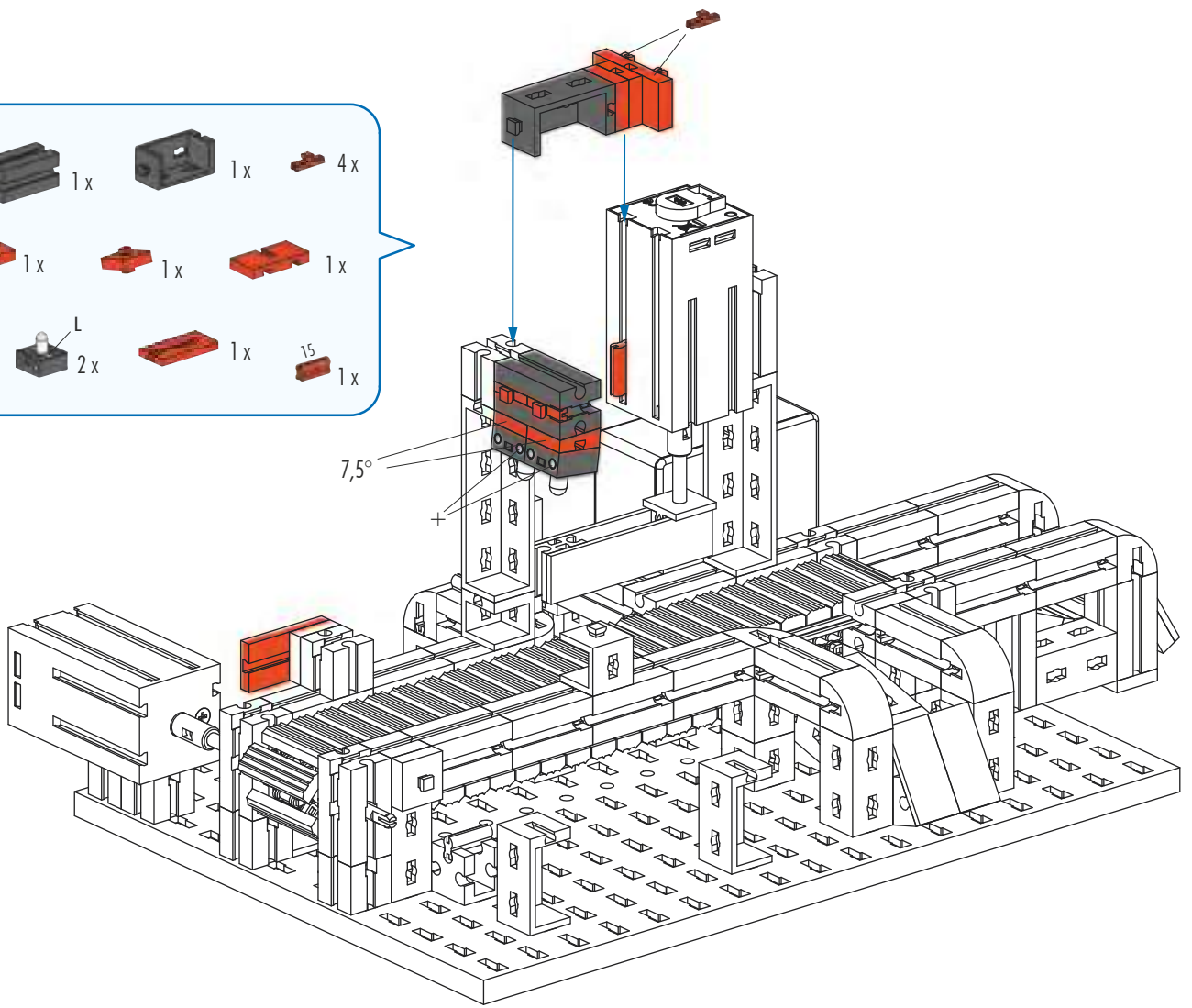

26

- 2x [Black 1x3 Technic Beam]
- 1x [Black 1x3 Technic Beam]
- 2x [Red 1x1 Technic Pin]
- 2x [Red 1x2 Technic Pin]
- 1x [Yellow 1x2 Technic Pin]
- 1x [Red 1x2 Technic Pin]
- 2x [Red 1x2 Technic Pin, 7.5°]
- 3x [Black L-shaped Technic Pin]
- 1x [Red 1x3 Technic Beam]

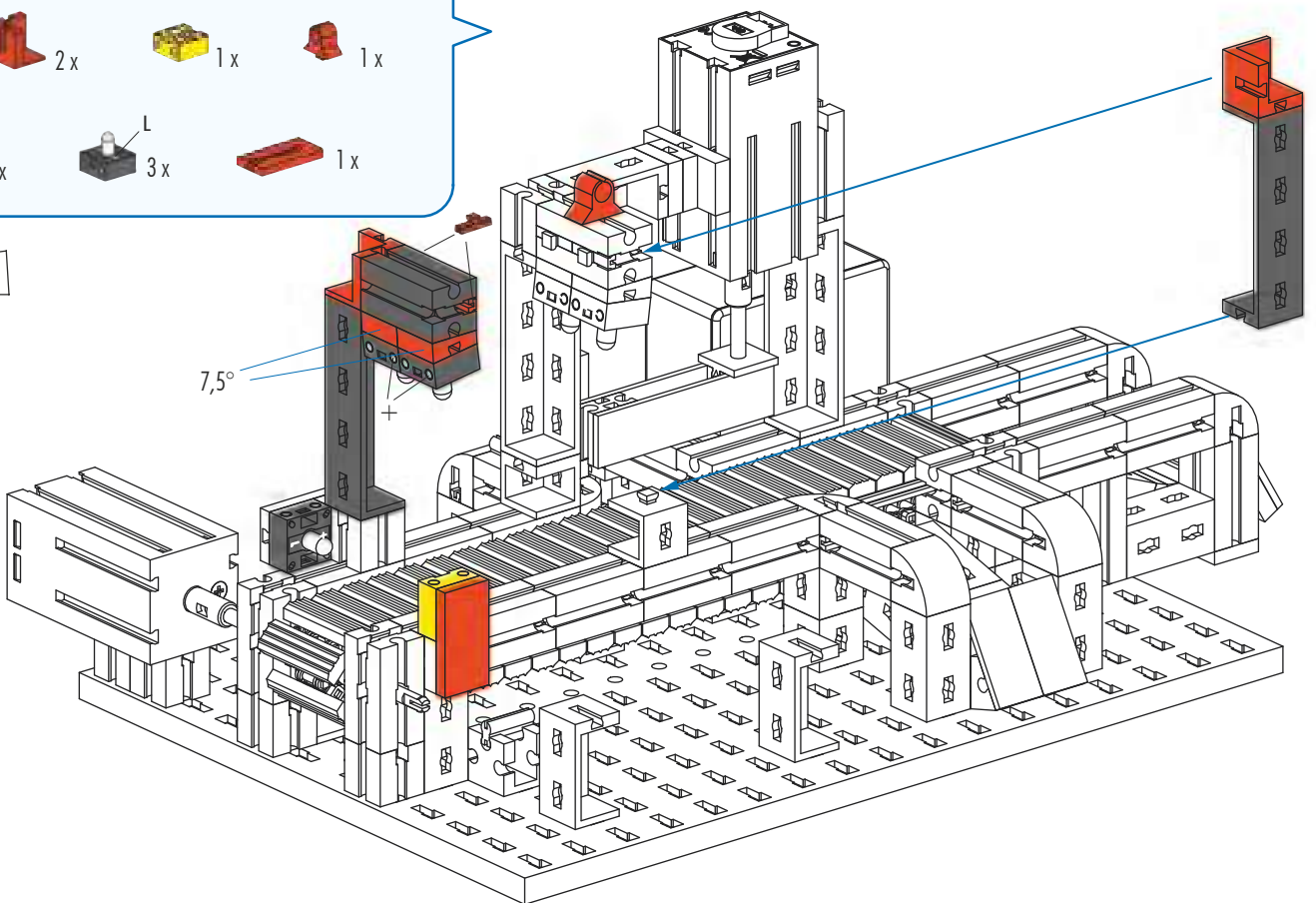

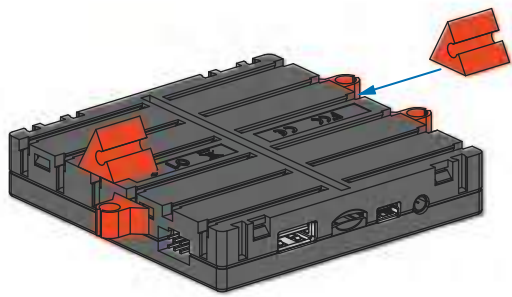

**27**

1x

60° 2x

2x

**28**

1x

2x

2x

W 1x

1x

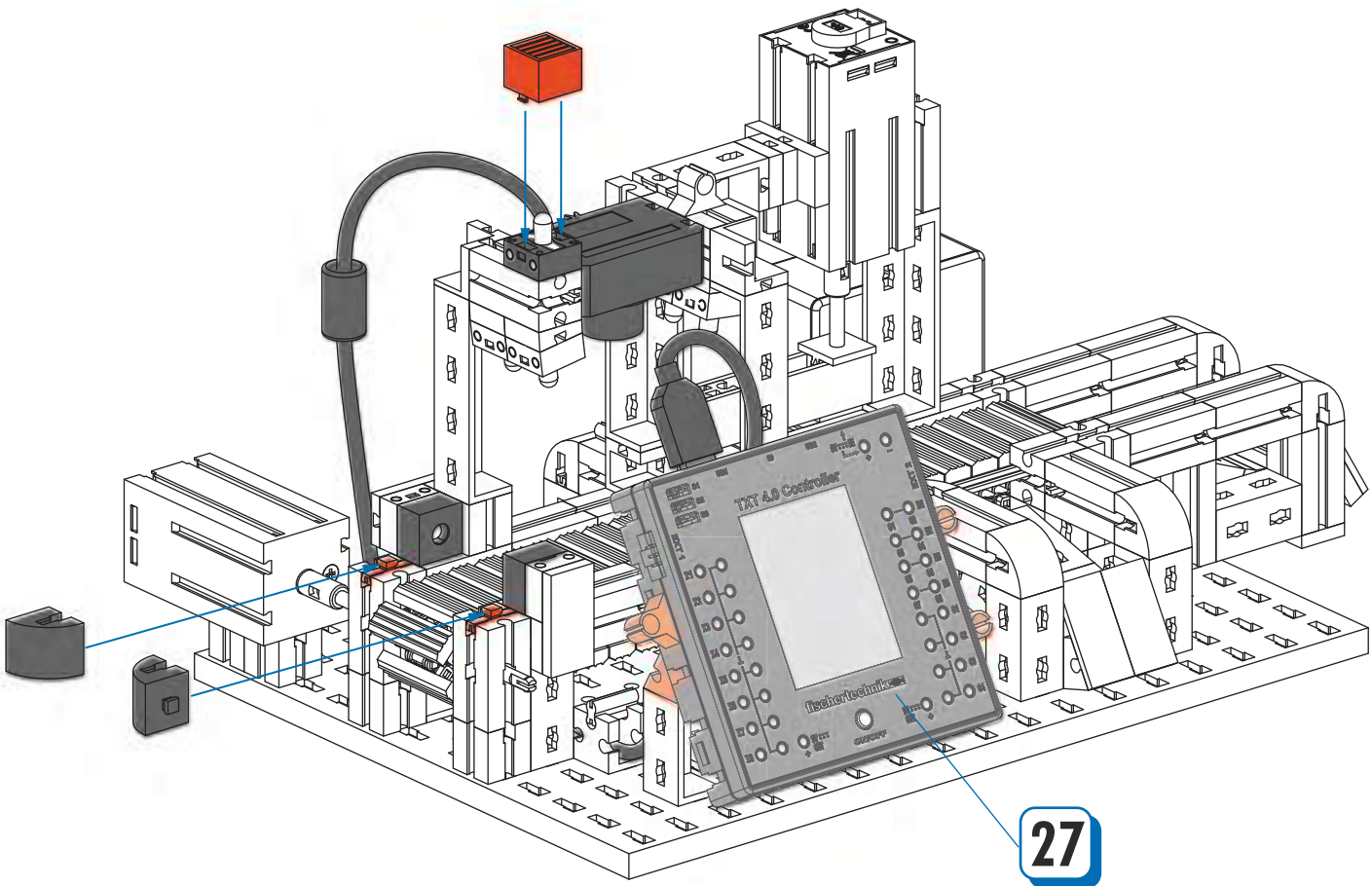



29

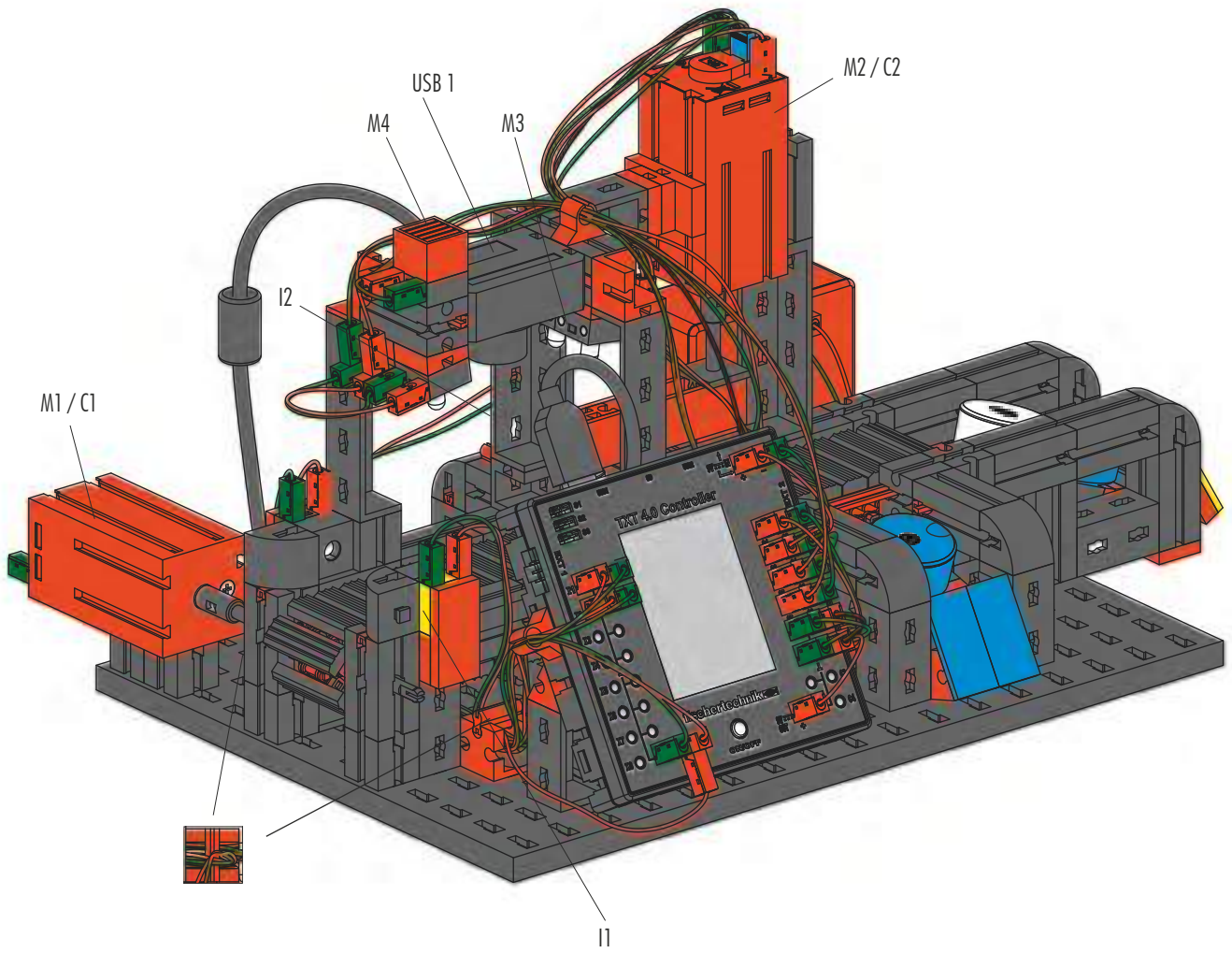
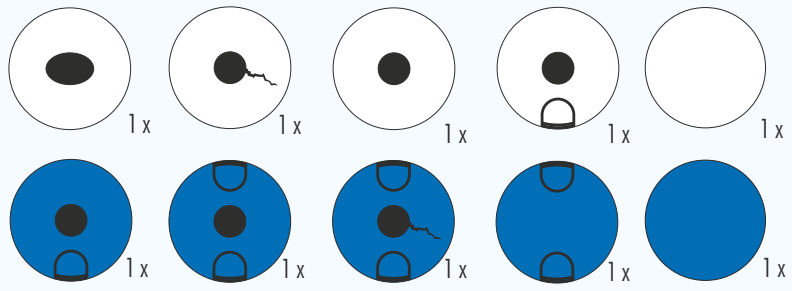

Schaltplan  
Circuit diagram  
Plan électrique

Schakelschema  
Diagrama de circuitos  
Plano elétrico de ligação

Schema elettrico  
Схема подключения  
电路图

